

# FK BEARINGS



Precision Rod Ends & Spherical Bearings



Welcome to FK Bearings Incorporated, a world-class leading manufacturer of rod ends, spherical bearings, custom-engineered bearings and related products. Established in 1983, FK Bearings brings over 35 years of experience to the industrial and performance racing industry.

Today, FK Bearings has grown to become the preferred source for motion control products to nearly every industry. Our products are utilized in various industries such as: construction, mining, material handling, transportation and off highway equipment, automation, machine tool, farming, robotics, military, agriculture, performance racing and many others.

FK Bearings corporate headquarters and state of the art manufacturing facility is located in Southington, Connecticut. Certified to ISO 9001 quality management system, based on process control, promotes continuous improvement throughout our entire organization setting the goals that keep FK Bearings the leader in motion transfer products. We have the largest ready to ship inventory in the industry as well as stocked warehouses in Indiana and California for the fastest and most efficient service anywhere in North America.

Fragola family owned and operated, we proudly put our name and reputation into every order we ship. We look forward to welcoming you into the FK family of satisfied customers.

Visit our website [www.fkrodends.com](http://www.fkrodends.com) or our social media partners: Twitter, Instagram and Facebook to see the latest in FK news, events and customer feedback. We showcase on social media our commitment to racing as there are few applications that abuse products like the racers do and we enjoy being in the winner's circle with our FK teams. Our commitment to the performance racing industry has set our standards in achieving the highest quality and unmatched customer service anywhere in the world.

Thank you for your interest in F.K. Bearings!

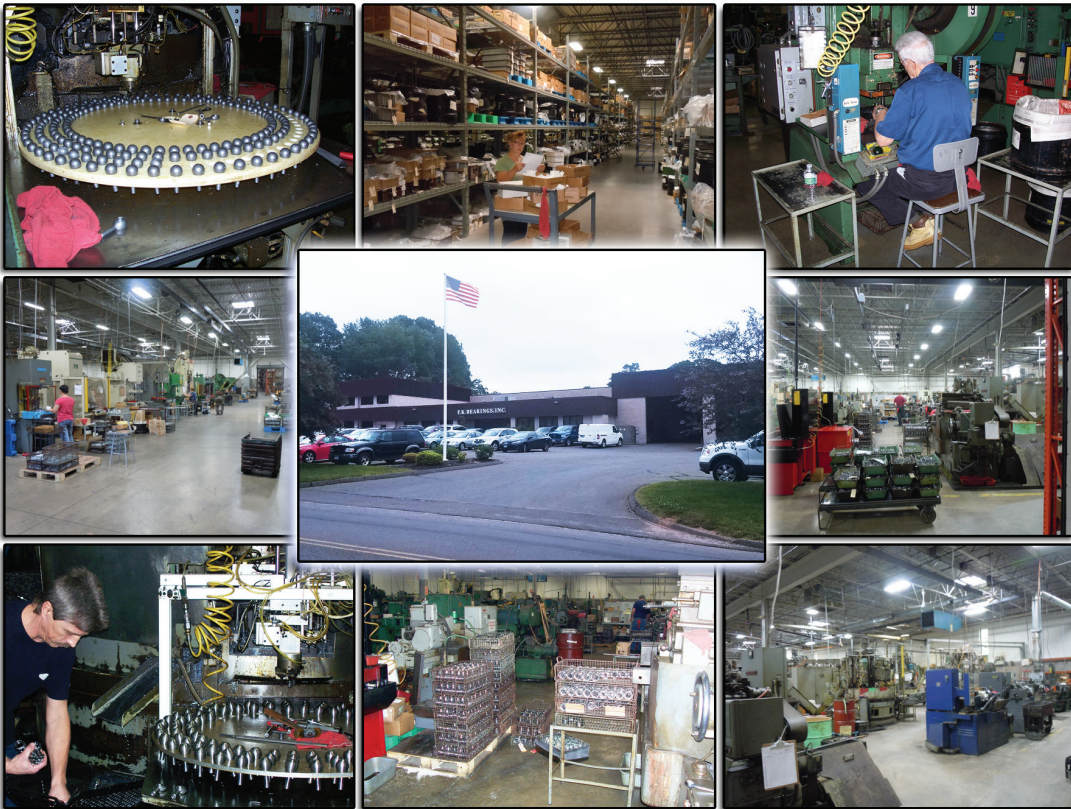

Proudly Made In  
Southington, Connecticut  
U.S.A.

## TABLE OF CONTENTS

COMMERCIAL INDUSTRIAL ROD ENDS		
CM / CF	2-piece, metal to metal	3
ECM / ECF	2-piece, Import, metal to metal	4
SCM-T / SCF-T	2-piece, stainless steel with PTFE liner	5
CMX / CFX	2-piece, metal to metal, heat treated, alloy steel	6
PRECISION SERIES ROD ENDS		
NJM / NJF	3-piece, plastic race	7
M-SB / F-SB	3-piece, sintered bronze race	8
JM / JML	3-piece, male, alloy steel race	9
JF / JFL	3-piece, female, alloy steel race	10
JMX / JMXL	3-piece, male, high strength alloy	11
JFX / JFXL	3-piece, female, high strength alloy	12
RJM / RJF	3-piece, precision, decorative chrome plated	13
RJMX-T / RJMXL-T	3-piece, male, high strength alloy, chrome or bright nickel plated with PTFE liner	14
KMX / KMXL	3-piece, male, high strength alloy steel with injected nylon race	15
SJM-T / SRSM-T / SJF-T	3-piece, stainless steel-wear resistant with PTFE liner	16
HJMX-T / HRSMX-T / HIN-T	High misalignment - rod ends and spherical bearings with PTFE liner	17
PMX-T / PMXL-T	3-piece, male, performance racing, stainless steel insert with PTFE liner	18
ALJM / ALJM-H / ALJF	3-piece, aluminum body	19
EXTRA-STRENGTH HEAVY DUTY SHANK		
ALRSM / ALRSM-L	3-piece, aluminum body	20
RSM / RSMX	3-piece, low carbon steel and alloy steel versions	21
EMX	3-piece, alloy steel	22
METRIC SERIES ROD ENDS		
CM-M / CF-M	2-piece, metric, metal to metal	23
SCM-MT / SCF-MT	2-piece, metric, stainless steel with PTFE liner	24
JM-M / JML-M	3-piece, metric, male, alloy steel race	25
JF-M / JFL-M	3-piece, metric, female, alloy steel race	26
JMX-M / JMXL-M	3-piece, metric, male, high strength alloy	27
JFX-M / JFXL-M	3-piece, metric, female, high strength alloy	28
SPHERICAL BEARINGS		
COM / COMH	Inch - commercial series, low carbon steel	29
COM-M	Metric - commercial series, low carbon steel	30
FKS / FKS-T	Precision narrow series, alloy steel, heat treated	31
FKSSX-T / FKSSX-TV	Precision narrow series, stainless steel with PTFE liner	32
WSSX-T / WSSX-TV	Precision wide series, stainless steel with PTFE liner	33
IN-P	Plastic race series	34
GEZ-ES	Inch - fractured race series	35
GE-ES	Metric - fractured race series	36
AIN	Heavy duty precision series, alloy steel	37
CP	Bearing cups	37
SPECIAL PRODUCTS		
SPECIAL SIZES	2-piece, metal to metal, special bore sizes	38
B	Ball joints	38
RD	Solid rod ends	39
CV	Clevis'	39
HB	High misalignment bushings	40
ADJUSTER LADDER	3/4" right to left hand turnbuckle	40
AJNR / AJNL	Jam nuts - inch, aluminum	41
SJNR / SJNL	Jam nuts - inch, steel	41
SJNR-M / SJNL-M	Jam nuts - metric, steel	41
CTR	Center finders for rod end adjustment lengths	41
RERS / WS	Rod end seals and boots to keep out the elements	42
WELDABLE TUBE ENDS	Threaded tube ends for rod end bearings	43
ADDITIONAL INFORMATION		
STUDS	Data for studded rod ends	45
ENGINEERING INFORMATION	Helpful information for choosing the correct product for your needs	44-45

# CM / CF

2-PIECE, METAL TO METAL / PTFE LINERS AVAILABLE

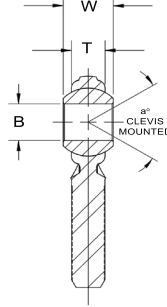
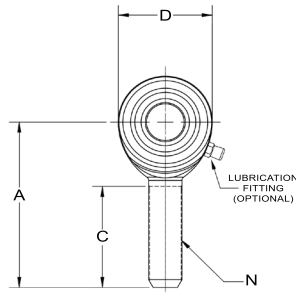

<b>BALL</b>
52100 STEEL Rc 56 MIN HARD CHROME PLATED
<b>BODY</b>
LOW CARBON STEEL ZINC PLATED CHROMATE TREATED
<b>LINER (OPTIONAL)</b>
PTFE FABRIC

MALE ROD ENDS		B DIA	D DIA	W WIDTH	T WIDTH	BALL DIA	A LGTH	N THD	C LGTH	a° MIS ANGLE	ULT. STATIC RADIAL LOAD		APPROX. WEIGHT (lbs.)	
RIGHT HAND PART NO.	LEFT HAND PART NO.										METAL TO METAL	PTFE LINED		
CM3 <sup>(1)</sup>	CML3 <sup>(1)</sup>	.1900 +.0025 -.0005	.625 REF.	.312 +.005 -.005	.234 REF.	.437 REF.	1.250 +.015 -.015	10-32 UNF 3A	.750 +.062 -.031	REF.	20	1,210	902	.03
CM4 <sup>(1)</sup>	CML4 <sup>(1)</sup>	.2500	.750	.375	.250	.500	1.562	1/4-28	1.000	27	2,225	1,809		.04
CM5 <sup>(1)</sup>	CML5 <sup>(1)</sup>	.3125	.875	.437	.312	.625	1.875	5/16-24	1.250	22	3,600	2,984		.07
CM6	CML6	.3750	1.000	.500	.359	.719	1.938	3/8-24	1.250	22	5,100	4,244		.11
CM7	CML7	.4375	1.125	.562	.406	.812	2.125	7/16-20	1.375	21	6,402	5,312		.15
CM8	CML8	.5000	1.312	.625	.453	.937	2.438	1/2-20	1.500	20	8,386	7,211		.24
CM10	CML10	.6250	1.500	.750	.484	1.125	2.625	5/8-18	1.625	26	9,813	8,403		.36
CM12	CML12	.7500	1.750	.875	.593	1.312	2.875	3/4-16	1.750	24	14,290	12,321		.57

MALE ROD END LOAD RATINGS BASED ON NO LUBRICATING FITTING. FOR LOAD RATINGS WITH LUBRICATOR, PLEASE CONTACT THE FK ENGINEERING DEPARTMENT.

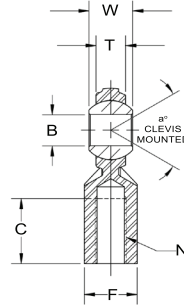
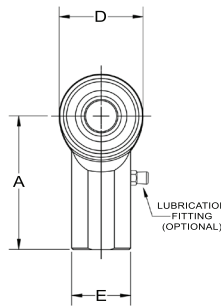

<b>BALL</b>
52100 STEEL Rc 56 MIN HARD CHROME PLATED
<b>BODY</b>
LOW CARBON STEEL ZINC PLATED CHROMATE TREATED
<b>LINER (OPTIONAL)</b>
PTFE FABRIC

FEMALE ROD ENDS		B DIA	D DIA	W WIDTH	T WIDTH	BALL DIA	A LGTH	N THD	C LGTH	E DIA.	F FLAT	a° MIS ANGLE	ULT. STATIC RADIAL LOAD		APPROX. WEIGHT (lbs.)	
RIGHT HAND PART NO.	LEFT HAND PART NO.												METAL TO METAL	PTFE LINED		
CF3 <sup>(1)</sup>	CFL3 <sup>(1)</sup>	.1900 +.0025 -.0005	.625 REF.	.312 +.005 -.005	.234 REF.	.437 REF.	1.062 +.015 -.015	10-32 UNF 2B	.500 +.062 -.031	.406 +.010 -.010	.312 +.010 -.010	REF.	20	2,100	1,637	.04
CF4-3	N/A	.2500	.750	.375	.250	.500	1.312	10-32	.687	.468	.375	27	3,250	-		.05
CF4	CFL4	.2500	.750	.375	.250	.500	1.312	1/4-28	.687	.468	.375	27	3,250	2,612		.05
CF5	CFL5	.3125	.875	.437	.312	.625	1.375	5/16-24	.687	.500	.437	22	3,934	3,110		.08
CF6	CFL6	.3750	1.000	.500	.359	.719	1.625	3/8-24	.812	.687	.562	22	5,100	4,206		.13
CF7	CFL7	.4375	1.125	.562	.406	.812	1.812	7/16-20	.937	.750	.625	21	6,420	5,384		.18
CF8	CFL8	.5000	1.312	.625	.453	.937	2.125	1/2-20	1.062	.875	.750	20	9,100	7,826		.29
CF10	CFL10	.6250	1.500	.750	.484	1.125	2.500	5/8-18	1.375	1.000	.875	26	9,800	8,343		.43
CF12	CFL12	.7500	1.750	.875	.593	1.312	2.875	3/4-16	1.562	1.125	1.000	24	14,250	12,342		.65

<sup>(1)</sup> GREASE FITTINGS ARE NOT SUPPLIED ON THESE SIZES

AVAILABLE OPTIONS	SUFFIX	EXAMPLE
PTFE LINER	T	CM10T
GREASE FITTING	Z	CM10Z
STUD (SEE PG 45 FOR STUD SPECS)	Y	CM10Y

<b>BALL</b>
52100 STEEL Rc 56 MIN. HARD CHROME PLATED
<b>BODY</b>
LOW CARBON STEEL ZINC PLATED CHROMATE TREATED

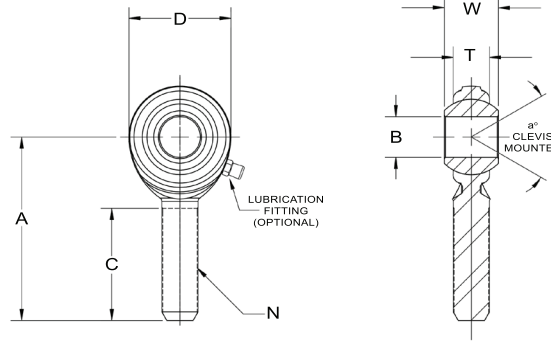

ECM / ECF  
2-PIECE, METAL TO METAL

MALE ROD ENDS		B DIA	D DIA	W WIDTH	T WIDTH	BALL DIA	A LGTH	N THD	C LGTH	a° MIS ANGLE	ULT. STATIC RADIAL LOAD	APPROX. WEIGHT (lbs.)
RIGHT HAND PART NO.	LEFT HAND PART NO.	+0.0025 -0.0005	REF.	+0.005 -0.005	REF.	REF.	+0.015 -0.015	UNF 3A	+0.062 -0.031	REF.		
ECM3 <sup>(1)</sup>	ECML3 <sup>(1)</sup>	.1900	.625	.312	.234	.437	1.250	10-32	.750	20	1,210	.03
ECM4 <sup>(1)</sup>	ECML4 <sup>(1)</sup>	.2500	.750	.375	.250	.500	1.562	1/4-28	1.000	27	2,225	.04
ECM5 <sup>(1)</sup>	ECML5 <sup>(1)</sup>	.3125	.875	.437	.312	.625	1.875	5/16-24	1.250	22	3,600	.07
ECM6	ECML6	.3750	1.000	.500	.359	.719	1.938	3/8-24	1.250	22	5,100	.11
ECM7	ECML7	.4375	1.125	.562	.406	.812	2.125	7/16-20	1.375	21	6,402	.15
ECM8	ECML8	.5000	1.312	.625	.453	.937	2.438	1/2-20	1.500	20	8,386	.24
ECM10	ECML10	.6250	1.500	.750	.484	1.125	2.625	5/8-18	1.625	26	9,813	.36
ECM12	ECML12	.7500	1.750	.875	.593	1.312	2.875	3/4-16	1.750	24	14,290	.57

MALE ROD END LOAD RATINGS BASED ON NO LUBRICATING FITTING. FOR LOAD RATINGS WITH LUBRICATOR, PLEASE CONTACT THE FK ENGINEERING DEPARTMENT.

<b>BALL</b>
52100 STEEL Rc 56 MIN. HARD CHROME PLATED
<b>BODY</b>
LOW CARBON STEEL ZINC PLATED CHROMATE TREATED

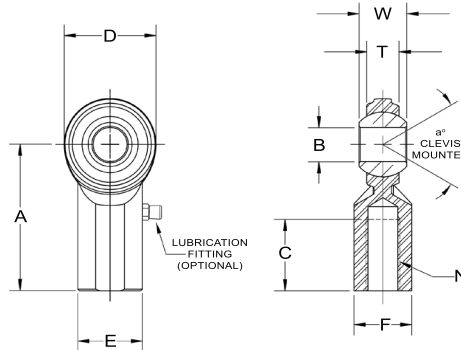

FEMALE ROD ENDS		B DIA	D DIA	W WIDTH	T WIDTH	BALL DIA	A LGTH	N THD	C LGTH	E DIA.	F FLAT	a° MIS ANGLE	ULT. STATIC RADIAL LOAD	APPROX. WEIGHT
RIGHT HAND PART NO.	LEFT HAND PART NO.	+0.0025 -0.0005	REF.	+0.005 -0.005	REF.	REF.	+0.015 -0.015	UNF 2B	+0.062 -0.031	+0.010 -0.010	+0.010 -0.010	REF.	(lbs.)	(lbs.)
ECF3 <sup>(1)</sup>	ECFL3 <sup>(1)</sup>	.1900	.625	.312	.234	.437	1.062	10-32	.500	.406	.312	20	2,100	.04
ECF4	ECFL4	.2500	.750	.375	.250	.500	1.312	1/4-28	.687	.468	.375	27	3,250	.05
ECF5	ECFL5	.3125	.875	.437	.312	.625	1.375	5/16-24	.687	.500	.437	22	3,934	.08
ECF6	ECFL6	.3750	1.000	.500	.359	.719	1.625	3/8-24	.812	.687	.562	22	5,100	.13
ECF7	ECFL7	.4375	1.125	.562	.406	.812	1.812	7/16-20	.937	.750	.625	21	6,420	.18
ECF8	ECFL8	.5000	1.312	.625	.453	.937	2.125	1/2-20	1.062	.875	.750	20	9,100	.29
ECF10	ECFL10	.6250	1.500	.750	.484	1.125	2.500	5/8-18	1.375	1.000	.875	26	9,800	.43
ECF12	ECFL12	.7500	1.750	.875	.593	1.312	2.875	3/4-16	1.562	1.125	1.000	24	14,250	.65

AVAILABLE OPTIONS	SUFFIX	EXAMPLE
GREASE FITTING	Z	ECM12Z
STUD (SEE PG 45 FOR STUD SPECS)	Y	ECM12Y

<sup>(1)</sup> GREASE FITTINGS ARE NOT SUPPLIED ON THESE SIZES

# SCM-T / SCF-T

2-PIECE, STAINLESS STEEL, PTFE LINED

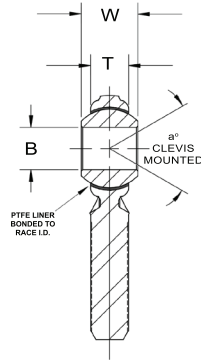
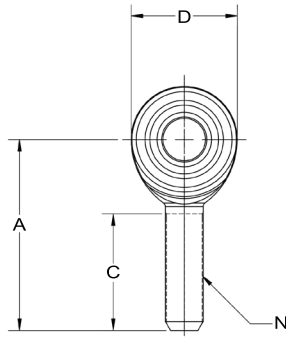

<b>BALL</b>
400 SERIES STAINLESS STEEL HEAT TREATED
<b>BODY</b>
303 STAINLESS STEEL
<b>LINER</b>
PTFE FABRIC

MALE ROD ENDS		B DIA	D DIA	W WIDTH	T WIDTH	BALL DIA	A LGTH	N THD	C LGTH	a° MIS ANGLE	ULT. STATIC RADIAL LOAD (lbs.)	APPROX. WEIGHT (lbs.)
RIGHT HAND PART NO.	LEFT HAND PART NO.	+.0025 -.0005	REF.	+.005 -.005	REF.	REF.	+.015 -.015	UNF 3A	+.062 -.031	REF.		
SCM3T	SCML3T	.1900	.625	.312	.234	.437	1.250	10-32	.750	20	912	.03
SCM4T	SCML4T	.2500	.750	.375	.250	.500	1.562	1/4-28	1.000	27	1,370	.04
SCM5T	SCML5T	.3125	.875	.437	.312	.625	1.875	5/16-24	1.250	22	2,050	.07
SCM6T	SCML6T	.3750	1.000	.500	.359	.719	1.938	3/8-24	1.250	22	3,040	.11
SCM7T	SCML7T	.4375	1.125	.562	.406	.812	2.125	7/16-20	1.375	21	3,780	.15
SCM8T	SCML8T	.5000	1.312	.625	.453	.937	2.438	1/2-20	1.500	20	4,700	.24
SCM10T	SCML10T	.6250	1.500	.750	.484	1.125	2.625	5/8-18	1.625	26	5,860	.36
SCM12T	SCML12T	.7500	1.750	.875	.593	1.312	2.875	3/4-16	1.750	24	7,512	.57

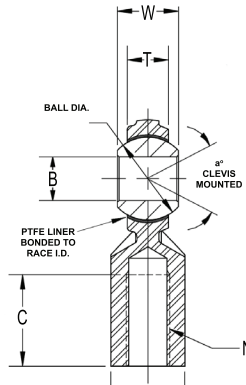
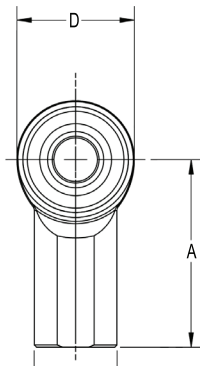

<b>BALL</b>
400 SERIES STAINLESS STEEL HEAT TREATED
<b>BODY</b>
303 STAINLESS STEEL
<b>LINER</b>
PTFE FABRIC

FEMALE ROD ENDS		B DIA	D DIA	W WIDTH	T WIDTH	BALL DIA	A LGTH	N THD	C LGTH	E DIA.	F FLAT	a° MIS ANGLE	ULT. STATIC RADIAL LOAD (lbs.)	APPROX. WEIGHT (lbs.)
RIGHT HAND PART NO.	LEFT HAND PART NO.	+.0025 -.0005	REF.	+.005 -.005	REF.	REF.	+.015 -.015	UNF 2B	+.062 -.031	+.010 -.010	+.010 -.010	REF.		
SCF3T	SCFL3T	.1900	.625	.312	.234	.437	1.062	10-32	.500	.406	.312	20	930	.04
SCF4T	SCFL4T	.2500	.750	.375	.250	.500	1.312	1/4-28	.687	.468	.375	27	1,380	.05
SCF5T	SCFL5T	.3125	.875	.437	.312	.625	1.375	5/16-24	.687	.500	.437	22	2,100	.08
SCF6T	SCFL6T	.3750	1.000	.500	.359	.719	1.625	3/8-24	.812	.687	.562	22	3,080	.13
SCF7T	SCFL7T	.4375	1.125	.562	.406	.812	1.812	7/16-20	.937	.750	.625	21	3,790	.18
SCF8T	SCFL8T	.5000	1.312	.625	.453	.937	2.125	1/2-20	1.062	.875	.750	20	4,720	.29
SCF10T	SCFL10T	.6250	1.500	.750	.484	1.125	2.500	5/8-18	1.375	1.000	.875	26	5,870	.43
SCF12T	SCFL12T	.7500	1.750	.875	.593	1.312	2.875	3/4-16	1.562	1.125	1.000	24	7,520	.65

SCM-T / SCF-T  
2-PIECE, STAINLESS STEEL, SELF LUBRICATING

<b>BALL</b>
52100 STEEL Rc 56 MIN HARD CHROME PLATED
<b>BODY</b>
ALLOY STEEL HEAT TREATED BLACK OXIDE TREATED
<b>LINER (OPTIONAL)</b>
PTFE FABRIC

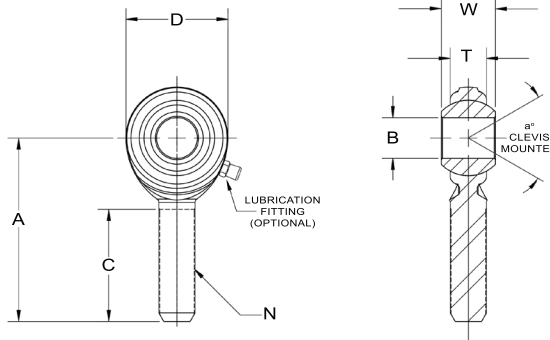

**CMX / CFX**  
2-PIECE, METAL TO METAL, HEAT TREATED, ALLOY STEEL

MALE ROD ENDS		B DIA	D DIA	W WIDTH	T WIDTH	BALL DIA	A LGTH	N THD	C LGTH	a° MIS AN- GLE	ULT. STATIC RADIAL LOAD		APPROX. WEIGHT (lbs.)
RIGHT HAND PART NO.	LEFT HAND PART NO.										METAL TO METAL	PTFE LINED	
CMX8	CMXL8	.5000 +.0025 -.0005	1.312 REF.	.625 +.005 -.005	.453 REF.	.937 REF.	2.438 +.015 -.015	1/2-20 UNF 3A	1.500 +.062 -.031	20 REF.	17,000*	14,500	.24
CMX10-8	CMXL10-8	.5000	1.500	.750	.484	1.125	2.625	5/8-18	1.625	26	18,000*	15,200	.30
CMX10	CMXL10	.6250	1.500	.750	.484	1.125	2.625	5/8-18	1.625	26	18,000*	15,200	.36
CMX12-8	CMXL12-8	.5000	1.750	.875	.593	1.312	2.875	3/4-16	1.750	24	25,000*	21,400	.57
CMX12-10	CMXL12-10	.6250	1.750	.875	.593	1.312	2.875	3/4-16	1.750	24	25,000*	21,400	.57
CMX12	CMXL12	.7500	1.750	.875	.593	1.312	2.875	3/4-16	1.750	24	25,000*	21,400	.57

\*MALE ROD END LOAD RATINGS BASED ON NO LUBRICATION FITTING. FOR LOAD RATINGS WITH LUBRICATOR, PLEASE CONTACT THE FK ENGINEERING DEPARTMENT.

<b>BALL</b>
52100 STEEL Rc 56 MIN HARD CHROME PLATED
<b>BODY</b>
ALLOY STEEL HEAT TREATED BLACK OXIDE TREATED
<b>LINER (OPTIONAL)</b>
PTFE FABRIC

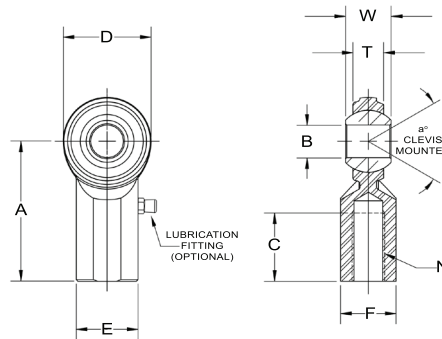

FEMALE ROD ENDS		B DIA	D DIA	W WIDTH	T WIDTH	BALL DIA	A LGTH	N THD	C LGTH	E DIA.	F FLAT	a° MIS AN- GLE	ULT. STATIC RADIAL LOAD		APPROX. WEIGHT (lbs.)
RIGHT HAND PART NO.	LEFT HAND PART NO.												METAL TO METAL	PTFE LINED	
CFX8	CFXL8	.5000 +.0025 -.0005	1.312 REF.	.625 +.005 -.005	.453 REF.	.937 REF.	2.125 +.015 -.015	1/2-20 UNF 2B	1.062 +.062 -.031	.875 +.010 -.010	.750 +.010 -.010	20 REF.	17,000	14,500	.24
CFX10	CFXL10	.6250	1.500	.750	.484	1.125	2.500	5/8-18	1.375	1.000	.875	26	18,000	15,200	.36
CFX12	CFXL12	.7500	1.750	.875	.593	1.312	2.875	3/4-16	1.562	1.125	1.000	24	25,000	21,400	.57

AVAILABLE OPTIONS	SUFFIX	EXAMPLE
PTFE LINER	T	CMX10T
GREASE FITTING	Z	CMX10Z
STUD (SEE PG 45 FOR STUD SPECS)	Y	CMX10Y

# NJM / NJF

3-PIECE, PRECISION - WEAR RESISTANT, PLASTIC RACE ROD ENDS

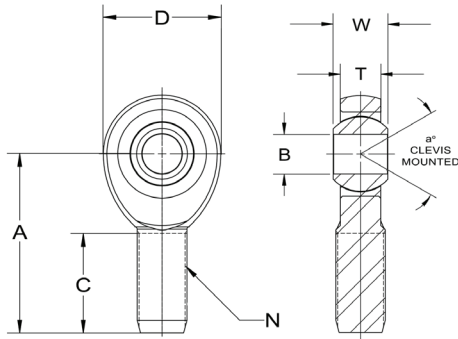

BALL	BODY
LOW CARBON STEEL CASE HARDENED ZINC PLATED	LOW CARBON STEEL CHROMATE TREATED ZINC PLATED
RACE	
CARBON FIBER REINFORCED, PTFE LUBRICATED	

NJM / NJF 3-PIECE, PRECISION - WEAR RESISTANT, PLASTIC RACE ROD ENDS

MALE ROD ENDS		B DIA	D DIA	W WIDTH	T WIDTH	BALL DIA	A LGTH	N THD	C LGTH	a° MIS ANGLE	ULT. STATIC RADIAL LOAD (lbs.)	APPROX. WEIGHT (lbs.)
RIGHT HAND PART NO.	LEFT HAND PART NO.	+0.0025 -0.0005	+0.010 -0.010	+0.005 -0.005	+0.015 -0.015	REF.	+0.015 -0.015	UNF 3A	+0.062 -0.031	REF.		
NJM3	NJML3	.1900	.625	.312	.250	.437	1.250	10-32	.750	13	1,174	.03
NJM4	NJML4	.2500	.750	.375	.281	.500	1.562	1/4-28	1.000	16	2,168	.04
NJM5	NJML5	.3125	.875	.437	.344	.625	1.875	5/16-24	1.250	14	2,796	.07
NJM6	NJML6	.3750	1.000	.500	.406	.719	1.938	3/8-24	1.250	12	4,012	.11
NJM7	NJML7	.4375	1.125	.562	.437	.812	2.125	7/16-20	1.375	14	4,244	.16
NJM8	NJML8	.5000	1.312	.625	.500	.937	2.438	1/2-20	1.500	12	6,453	.25
NJM10	NJML10	.6250	1.500	.750	.562	1.125	2.625	5/8-18	1.625	16	7,400	.38
NJM12	NJML12	.7500	1.750	.875	.687	1.312	2.875	3/4-16	1.750	14	10,937	.60

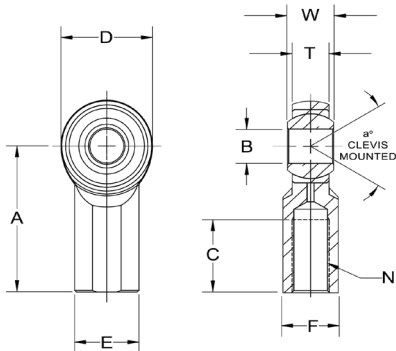

BALL	BODY
LOW CARBON STEEL CASE HARDENED ZINC PLATED	LOW CARBON STEEL CHROMATE TREATED ZINC PLATED
RACE	
CARBON FIBER REINFORCED, PTFE LUBRICATED	

FEMALE ROD ENDS		B DIA	D DIA	W WIDTH	T WIDTH	BALL DIA	A LGTH	N THD	C LGTH	E DIA.	F FLAT	a° MIS ANGLE	ULT. STATIC RADIAL LOAD (lbs.)	APPROX. WEIGHT (lbs.)
RIGHT HAND PART NO.	LEFT HAND PART NO.	+0.0025 -0.0005	+0.010 -0.010	+0.005 -0.005	+0.015 -0.015	REF.	+0.015 -0.015	UNF 2B	+0.062 -0.031	+0.010 -0.010	+0.010 -0.010	REF.		
NJF3	NJFL3	.1900	.625	.312	.250	.437	1.062	10-32	.500	.406	.312	13	1,220	.04
NJF4	NJFL4	.2500	.750	.375	.281	.500	1.312	1/4-28	.687	.469	.375	16	2,500	.06
NJF5	NJFL5	.3125	.875	.437	.344	.625	1.375	5/16-24	.687	.500	.437	14	2,753	.09
NJF6	NJFL6	.3750	1.000	.500	.406	.719	1.625	3/8-24	.812	.687	.562	12	3,950	.15
NJF7	NJFL7	.4375	1.125	.562	.437	.812	1.812	7/16-20	.937	.750	.625	14	4,300	.20
NJF8	NJFL8	.5000	1.312	.625	.500	.937	2.125	1/2-20	1.062	.875	.750	12	6,453	.33
NJF10	NJFL10	.6250	1.500	.750	.562	1.125	2.500	5/8-18	1.375	1.000	.875	16	7,400	.48
NJF12	NJFL12	.7500	1.750	.875	.687	1.312	2.875	3/4-16	1.562	1.125	1.000	14	10,937	.72

AVAILABLE OPTIONS	SUFFIX	EXAMPLE
STUD (SEE PG 45 FOR STUD SPECS)	Y	NJM10Y

# M-SB / F-SB

3-PIECE, COMMERCIAL, SINTERED BRONZE

BALL	BODY
52100 STEEL Rc 56 MIN. HARD HARD CHROME PLATED	LOW CARBON STEEL ZINC PLATED CHROMATE TREATED
RACE	
SINTERED PHOSPHOR BRONZE OIL IMPREGNATED	

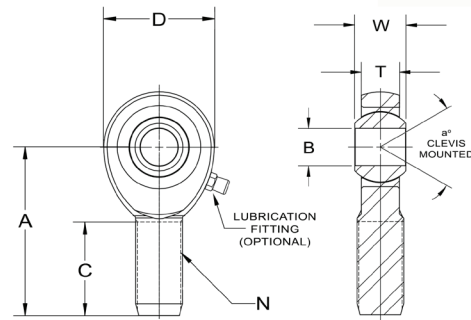

MALE ROD ENDS		B DIA	D DIA	W WIDTH	T WIDTH	BALL DIA	A LGTH	N THD	C LGTH	a° MIS ANGLE	ULT. STATIC RADIAL LOAD (lbs.)	APPROX. WEIGHT (lbs.)
RIGHT HAND PART NO.	LEFT HAND PART NO.	+0.0025 -0.0005	+0.010 -0.010	+0.005 -0.005	+0.015 -0.015	REF.	+0.015 -0.015	UNF 3A	+0.062 -0.031	REF.		
M3SB	ML3SB	.1900	.625	.312	.250	.437	1.250	10-32	.750	13	1,174	.03
M4SB	ML4SB	.2500	.750	.375	.281	.500	1.562	1/4-28	1.000	16	2,168	.04
M5SB	ML5SB	.3125	.875	.437	.344	.625	1.875	5/16-24	1.250	14	2,796	.07
M6SB	ML6SB	.3750	1.000	.500	.406	.719	1.938	3/8-24	1.250	12	4,012	.11
M7SB	ML7SB	.4375	1.125	.562	.437	.812	2.125	7/16-20	1.375	14	4,244	.16
M8SB	ML8SB	.5000	1.312	.625	.500	.937	2.438	1/2-20	1.500	12	6,700	.25
M10SB	ML10SB	.6250	1.500	.750	.562	1.125	2.625	5/8-18	1.625	16	7,400	.38
M12SB	ML12SB	.7500	1.750	.875	.687	1.312	2.875	3/4-16	1.750	14	11,550	.60

BALL	BODY
52100 STEEL Rc 56 MIN. HARD HARD CHROME PLATED	LOW CARBON STEEL ZINC PLATED CHROMATE TREATED
RACE	
SINTERED PHOSPHOR BRONZE OIL IMPREGNATED	

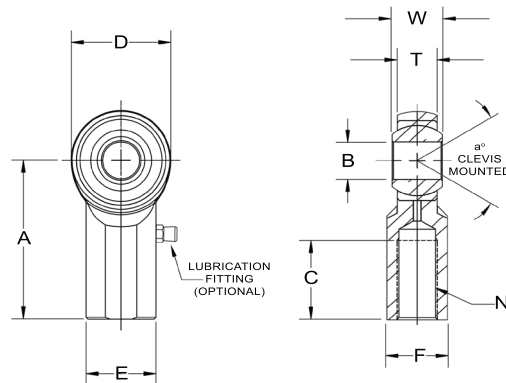

FEMALE ROD ENDS		B DIA	D DIA	W WIDTH	T WIDTH	BALL DIA	A LGTH	N THD	C LGTH	E DIA.	F FLAT	a° MIS ANGLE	ULT. STATIC RADIAL LOAD (lbs.)	APPROX. WEIGHT (lbs.)
RIGHT HAND PART NO.	LEFT HAND PART NO.	+0.0025 -0.0005	+0.010 -0.010	+0.005 -0.005	+0.015 -0.015	REF.	+0.015 -0.015	UNF 2B	+0.062 -0.031	+0.010 -0.010	+0.010 -0.010	REF.		
F3SB	FL3SB	.1900	.625	.312	.250	.437	1.062	10-32	.500	.406	.312	13	1,624	.04
F4SB	FL4SB	.2500	.750	.375	.281	.500	1.312	1/4-28	.687	.468	.375	16	2,545	.06
F5SB	FL5SB	.3125	.875	.437	.344	.625	1.375	5/16-24	.687	.500	.437	14	3,200	.09
F6SB	FL6SB	.3750	1.000	.500	.406	.719	1.625	3/8-24	.812	.687	.562	12	3,950	.15
F7SB	FL7SB	.4375	1.125	.562	.437	.812	1.812	7/16-20	.937	.750	.625	14	4,300	.20
F8SB	FL8SB	.5000	1.312	.625	.500	.937	2.125	1/2-20	1.062	.875	.750	12	6,700	.33
F10SB	FL10SB	.6250	1.500	.750	.562	1.125	2.500	5/8-18	1.375	1.000	.875	16	7,400	.48
F12SB	FL12SB	.7500	1.750	.875	.687	1.312	2.875	3/4-16	1.562	1.125	1.000	14	11,550	.72

AVAILABLE OPTIONS	SUFFIX	EXAMPLE
GREASE FITTING	Z	M10SBZ
STUD (SEE PG 45 FOR STUD SPECS)	Y	M1010SBY

M-SB / F-SB  
3-PIECE, COMMERCIAL, SINTERED BRONZE

# JM / JML

3-PIECE, PRECISION - WEAR RESISTANT / PTFE LINERS AVAILABLE

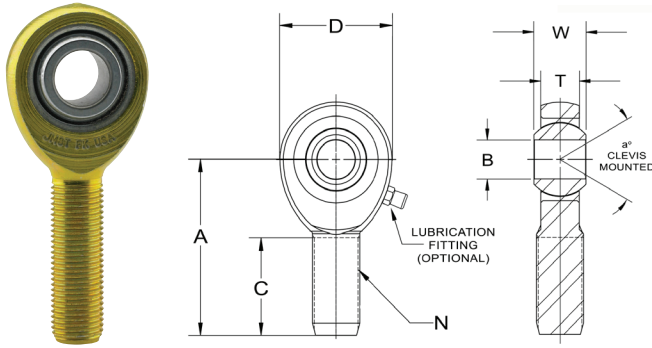

BALL	BODY
52100 STEEL Rc 56 MIN HARD HARD CHROME PLATED	LOW CARBON STEEL ZINC PLATED CHROMATE TREATED
RACE	
STEEL ALLOY - HEAT TREATED ZINC PLATED CHROMATE TREATED	
LINER (OPTIONAL)	
PTFE FABRIC	

MALE ROD ENDS		B DIA	D DIA	W WIDTH	T WIDTH	BALL DIA	A LGTH	N THD	C LGTH	a° MIS ANGLE	ULT. STATIC RADIAL LOAD (lbs.)	APPROX. WEIGHT (lbs.)
RIGHT HAND PART NO.	LEFT HAND PART NO.											
		+0.025 -0.005	+0.010 -0.010	+0.005 -0.005	+0.015 -0.015	REF.	+0.015 -0.015	UNF 3A	+0.062 -0.031	REF.		
JM2 <sup>(1)</sup>	JML2 <sup>(1)</sup>	.1250	.500	.250	.187	.312	.937	6-32 UNC	.562	16	500	.013
JM3	JML3	.1900	.625	.312	.250	.437	1.250	10-32	.750	13	1,174	.03
JM4	JML4	.2500	.750	.375	.281	.500	1.562	1/4-28	1.000	16	2,168	.04
JM5	JML5	.3125	.875	.437	.344	.625	1.875	5/16-24	1.250	14	2,796	.07
JM6	JML6	.3750	1.000	.500	.406	.719	1.938	3/8-24	1.250	12	4,012	.11
JM7	JML7	.4375	1.125	.562	.437	.812	2.125	7/16-20	1.375	14	4,244	.16
JM8	JML8	.5000	1.312	.625	.500	.937	2.438	1/2-20	1.500	12	6,700	.25
JM10	JML10	.6250	1.500	.750	.562	1.125	2.625	5/8-18	1.625	16	7,400	.38
JM12	JML12	.7500	1.750	.875	.687	1.312	2.875	3/4-16	1.750	14	11,550	.60
JM14	JML14	.8750	2.000	.875	.687	1.312	3.375	7/8-14	1.875	12	22,850	.91
JM14-770	JML14-770	.8750	2.000	.875	.770	1.375	3.375	7/8-14	1.875	12	18,490	.91
JM16 <sup>(2)(3)</sup>	JML16 <sup>(2)(3)</sup>	1.0000	2.950	1.375	1.015	1.875	4.500	1-1/4-12	2.500	17	43,555	2.736
JM16-1 <sup>(2)(3)</sup>	JML16-1 <sup>(2)(3)</sup>	1.0000	2.950	1.375	1.015	1.875	4.500	1-14	2.500	17	43,555	2.464
JM16-2 <sup>(2)(3)</sup>	JML16-2 <sup>(2)(3)</sup>	1.0000	2.950	1.375	1.015	1.875	4.500	1-12	2.500	17	43,555	2.464
JM20 <sup>(2)(3)</sup>	JML20 <sup>(2)(3)</sup>	1.250	2.950	1.250	1.015	1.875	4.500	1 1/4-12	2.500	11	43,555	2.736
JM24 <sup>(2)(3)</sup>	JML24 <sup>(2)(3)</sup>	1.5000	3.500	1.375	1.125	2.312	5.375	1 1/2-12	3.000	8.75	66,450	4.75
JM32 <sup>(2)(3)(4)</sup>	JML32 <sup>(2)(3)(4)</sup>	2.000	5.010	1.750	1.437	2.937	8.020	2-12	4.500	7.5	163,750	14.25

MALE ROD END LOAD RATINGS BASED ON NO LUBRICATION FITTING. FOR LOAD RATINGS WITH LUBRICATOR, PLEASE CONTACT THE FK ENGINEERING DEPARTMENT.

- (1) GREASE FITTINGS & PTFE LINERS NOT AVAILABLE.
- (2) TOLERANCE VARIATION FOR "D" & "A" ARE +/- .020
- (3) AVAILABLE IN CLEAR ZINC ONLY
- (4) CHECK FOR AVAILABILITY

AVAILABLE OPTIONS	SUFFIX	EXAMPLE
PTFE LINER	T	JM10T
GREASE FITTING	Z	JM10Z
STUD (SEE PG 45 FOR STUD SPECS)	Y	JM10Y

BALL	BODY
52100 STEEL Rc 56 MIN HARD HARD CHROME PLATED	LOW CARBON STEEL ZINC PLATED CHROMATE TREATED
RACE	
STEEL ALLOY - HEAT TREATED ZINC PLATED CHROMATE TREATED	
LINER (OPTIONAL)	
PTFE FABRIC	

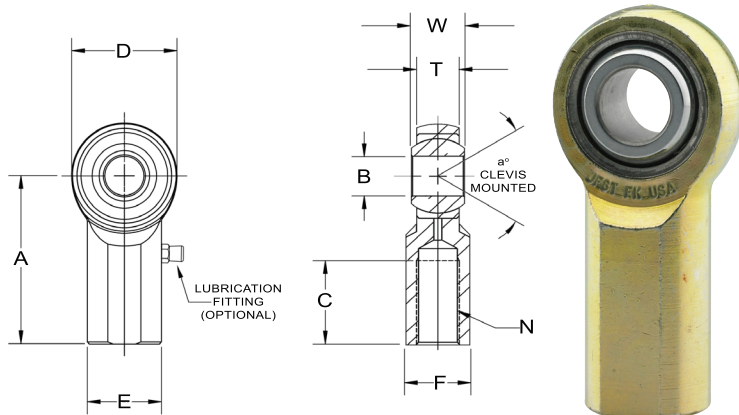

FEMALE ROD ENDS		B DIA	D DIA	W WIDTH	T WIDTH	BALL DIA	A LGTH	N THD	C LGTH	E DIA.	F FLAT	a° MIS ANGLE	ULT. STATIC RADIAL LOAD (lbs.)	APPROX. WEIGHT (lbs.)
RIGHT HAND PART NO.	LEFT HAND PART NO.													
		+0.0025 -0.0005	+0.010 -0.010	+0.005 -0.005	+0.015 -0.015	REF.	+0.015 -0.015	UNF 2B	+0.062 -0.031	+0.010 -0.010	+0.010 -0.010	REF.		
JF2 <sup>(1)</sup>	JFL2 <sup>(1)</sup>	.1250	.500	.250	.187	.312	.812	6-32 UNC	.437	.312	.250	16	1,210	.019
JF3	JFL3	.1900	.625	.312	.250	.437	1.062	10-32	.500	.406	.312	13	1,624	.04
JF4	JFL4	.2500	.750	.375	.281	.500	1.312	1/4-28	.687	.469	.375	16	2,545	.06
JF5	JFL5	.3125	.875	.437	.344	.625	1.375	5/16-24	.687	.500	.437	14	3,200	.09
JF6	JFL6	.3750	1.000	.500	.406	.719	1.625	3/8-24	.812	.687	.562	12	3,950	.15
JF7	JFL7	.4375	1.125	.562	.437	.812	1.812	7/16-20	.937	.750	.625	14	4,300	.20
JF8	JFL8	.5000	1.312	.625	.500	.937	2.125	1/2-20	1.062	.875	.750	12	6,700	.33
JF10	JFL10	.6250	1.500	.750	.562	1.125	2.500	5/8-18	1.375	1.000	.875	16	7,400	.48
JF12	JFL12	.7500	1.750	.875	.687	1.312	2.875	3/4-16	1.562	1.125	1.000	14	11,550	.72
JF16 <sup>(2)(3)</sup>	JFL16 <sup>(2)(3)</sup>	1.0000	2.750	1.375	1.000	1.875	4.125	1-1/4-12	2.125	1.625	1.500	17	40,893	2.125
JF16-1 <sup>(2)(3)</sup>	JFL16-1 <sup>(2)(3)</sup>	1.0000	2.750	1.375	1.000	1.875	4.125	1-14	2.125	1.625	1.500	17	43,555	2.410
JF16-2 <sup>(2)(3)</sup>	JFL16-2 <sup>(2)(3)</sup>	1.0000	2.750	1.375	1.000	1.875	4.125	1-12	2.125	1.625	1.500	17	43,555	2.410
JF20 <sup>(2)(3)</sup>	JFL20 <sup>(2)(3)</sup>	1.250	2.750	1.250	1.000	1.875	4.125	1 1/4-12	2.125	1.625	1.500	11	40,893	2.125

- (1) GREASE FITTINGS & PTFE LINERS NOT AVAILABLE.
- (2) TOLERANCE VARIATION FOR "D" & "A" ARE +/- .020
- (3) AVAILABLE IN CLEAR ZINC ONLY

AVAILABLE OPTIONS	SUFFIX	EXAMPLE
PTFE LINER	T	JF10T
GREASE FITTING	Z	JF10Z
STUD (SEE PG 45 FOR STUD SPECS)	Y	JF10Y

**JF / JFL**  
3-PIECE, PRECISION - WEAR RESISTANT

# JMX / JMXL

3-PIECE, PRECISION - HIGH STRENGTH ALLOY / PTFE LINERS AVAILABLE

JMX / JMXL  
3-PIECE, PRECISION - HIGH STRENGTH ALLOY

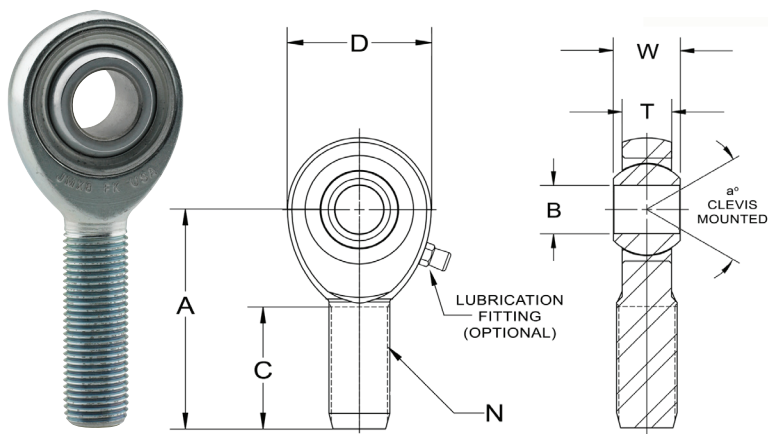

BALL	BODY
52100 STEEL Rc 56 MIN HARD HARD CHROME PLATED	STEEL ALLOY-HEAT TREATED ZINC PLATED CHROMATE TREATED
RACE	
STEEL ALLOY - HEAT TREATED ZINC PLATED CHROMATE TREATED	
LINER (OPTIONAL)	
PTFE FABRIC	

MALE ROD ENDS		B DIA	D DIA	W WIDTH	T WIDTH	BALL DIA	A LGTH	N THD	C LGTH	a° MIS ANGLE	ULT. STATIC RADIAL LOAD (lbs.)	APPROX. WEIGHT (lbs.)
RIGHT HAND PART NO.	LEFT HAND PART NO.											
JMX3	JMXL3	.1900 +.0025 -.0005	.625 +.010 -.010	.312 +.005 -.005	.250 +.005 -.005	.437 REF.	1.250 +.015 -.015	10-32 UNF 3A	.750 +.062 -.031	13 REF.	2,855	.03
JMX4	JMXL4	.2500	.750	.375	.281	.500	1.562	1/4-28	1.000	16	5,262	.04
JMX5	JMXL5	.3125	.875	.437	.344	.625	1.875	5/16-24	1.250	14	7,640	.07
JMX6	JMXL6	.3750	1.000	.500	.406	.719	1.938	3/8-24	1.250	12	9,550	.11
JMX7	JMXL7	.4375	1.125	.562	.437	.812	2.125	7/16-20	1.375	14	10,290	.16
JMX8	JMXL8	.5000	1.312	.625	.500	.937	2.438	1/2-20	1.500	12	16,242	.25
JMX8-6	JMXL8-6	.3750	1.312	.625	.500	.937	2.438	1/2-20	1.500	12	16,242	.25
JMX10	JMXL10	.6250	1.500	.750	.562	1.125	2.625	5/8-18	1.625	16	17,959	.38
JMX12	JMXL12	.7500	1.750	.875	.687	1.312	2.875	3/4-16	1.750	14	28,090	.60
JMX14	JMXL14	.8750	2.000	.875	.687	1.312	3.375	7/8-14	1.875	12	55,690	.91
JMX14-770	JMXL14-770	.8750	2.000	.875	.770	1.375	3.375	7/8-14	1.875	12	45,051	.91
JMX16 <sup>(1)</sup>	JMXL16 <sup>(1)</sup>	1.0000	2.950	1.375	1.015	1.875	4.500	1 1/4-12	2.500	17	107,182	2.736
JMX16-1 <sup>(1)</sup>	JMXL16-1 <sup>(1)</sup>	1.0000	2.950	1.375	1.015	1.875	4.500	1-14	2.500	17	107,182	2.464
JMX20 <sup>(1)</sup>	JMXL20 <sup>(1)</sup>	1.250	2.950	1.250	1.015	1.875	4.500	1 1/4-12	2.500	11	107,182	2.736
JMX24 <sup>(1)</sup>	JMXL24 <sup>(1)</sup>	1.5000	3.500	1.375	1.125	2.312	5.375	1 1/2-12	3.000	8.75	136,750	4.75
JMX32 <sup>(1)(2)</sup>	JMXL32 <sup>(1)(2)</sup>	2.000	5.010	1.750	1.437	2.937	8.020	2-12	4.500	7.5	281,150	14.25

\*MALE ROD END LOAD RATINGS BASED ON NO LUBRICATION FITTING. FOR LOAD RATINGS WITH LUBRICATOR, PLEASE CONTACT THE FK ENGINEERING DEPARTMENT.

(1) TOLERANCE VARIATION FOR "D" & "A" ARE +/- .020

(2) CHECK FOR AVAILABILITY

AVAILABLE OPTIONS	SUFFIX	EXAMPLE
PTFE LINER	T	JMX10T
GREASE FITTING	Z	JMX10Z
STUD (SEE PG 45 FOR STUD SPECS)	Y	JMX10Y

BALL	BODY
52100 STEEL Rc 56 MIN HARD HARD CHROME PLATED	STEEL ALLOY-HEAT TREATED ZINC PLATED CHROMATE TREATED
RACE	
STEEL ALLOY - HEAT TREATED ZINC PLATED CHROMATE TREATED	
LINER (OPTIONAL)	
PTFE FABRIC	

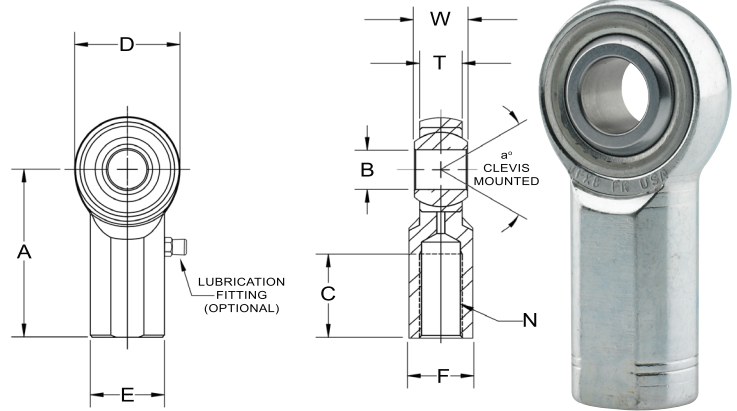

**JFX / JFXL**  
3-PIECE, PRECISION - HIGH STRENGTH ALLOY

FEMALE ROD ENDS		B DIA	D DIA	W WIDTH	T WIDTH	BALL DIA	A LGTH	N THD	C LGTH	E DIA.	F FLAT	a° MIS ANGLE	ULT. STATIC RADIAL LOAD (lbs.)	APPROX. WEIGHT (lbs.)
RIGHT HAND PART NO.	LEFT HAND PART NO.	+0.0025 -0.0005	+0.010 -0.010	+0.005 -0.005	+0.005 -0.005	REF.	+0.015 -0.015	UNF 2B	+0.062 -0.031	+0.010 -0.010	+0.010 -0.010	REF.		
JFX3	JFXL3	.1900	.625	.312	.250	.437	1.062	10-32	.562	.406	.312	13	3,736	.04
JFX4	JFXL4	.2500	.750	.375	.281	.500	1.312	1/4-28	.750	.469	.375	16	6,195	.06
JFX5	JFXL5	.3125	.875	.437	.344	.625	1.375	5/16-24	.750	.500	.437	14	7,640	.09
JFX6	JFXL6	.3750	1.000	.500	.406	.719	1.625	3/8-24	.937	.687	.562	12	9,550	.15
JFX7	JFXL7	.4375	1.125	.562	.437	.812	1.812	7/16-20	1.062	.750	.625	14	10,290	.20
JFX8	JFXL8	.5000	1.312	.625	.500	.937	2.125	1/2-20	1.187	.875	.750	12	15,340	.33
JFX10	JFXL10	.6250	1.500	.750	.562	1.125	2.500	5/8-18	1.500	1.000	.875	16	17,959	.48
JFX12	JFXL12	.7500	1.750	.875	.687	1.312	2.875	3/4-16	1.750	1.125	1.000	14	28,090	.72
JFX14	JFXL14	.8750	2.000	.875	.770	1.375	3.375	7/8-14	1.875	1.300	1.125	7	45,051	1.03
JFX16 <sup>(1)</sup>	JFXL16 <sup>(1)</sup>	1.0000	2.750	1.375	1.000	1.875	4.125	1-1/4-12	2.125	1.625	1.500	17	76,205	2.125
JFX16-1 <sup>(1)</sup>	JFXL16-1 <sup>(1)</sup>	1.0000	2.750	1.375	1.000	1.875	4.125	1-14	2.125	1.625	1.500	17	76,205	2.410
JFX20 <sup>(1)</sup>	JFXL20 <sup>(1)</sup>	1.250	2.750	1.250	1.000	1.875	4.125	1 1/4-12	2.125	1.625	1.500	11	76,205	2.125
JFX24-1 <sup>(1)</sup>	JFXL24-1 <sup>(1)</sup>	1.500	3.500	1.312	1.125	2.155	5.375	1 1/2-12	2.625	2.250	2.000	6.5	138,800	6.50

\*MALE ROD END LOAD RATINGS BASED ON NO LUBRICATION FITTING. FOR LOAD RATINGS WITH LUBRICATOR, PLEASE CONTACT THE FK ENGINEERING DEPARTMENT.

<sup>(1)</sup> TOLERANCE VARIATION FOR "D" & "A" ARE +/- .020

AVAILABLE OPTIONS	SUFFIX	EXAMPLE
PTFE LINER	T	JFX10T
GREASE FITTING	Z	JFX10Z
STUD (SEE PG 45 FOR STUD SPECS)	Y	JFX10Y

# RJM / RJF

3-PIECE, PRECISION - CHROME PLATED / PTFE LINERS AVAILABLE

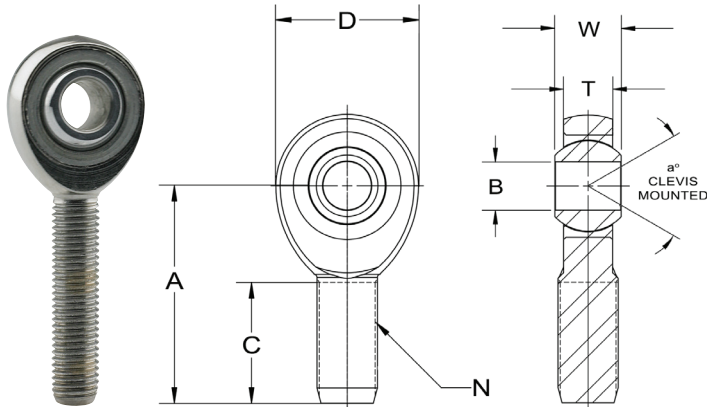

BALL	BODY
52100 STEEL Rc 56 MIN HARD CHROME PLATED	LOW CARBON STEEL DECORATIVE CHROME PLATED
RACE	
STEEL ALLOY - HEAT TREATED ZINC PLATED CHROMATE TREATED	
LINER (OPTIONAL)	
PTFE FABRIC	

MALE ROD ENDS		B DIA	D DIA	W WIDTH	T WIDTH	BALL DIA	A LGTH	N THD	C LGTH	a° MIS ANGLE	ULT. STATIC RADIAL LOAD (lbs.)	APPROX. WEIGHT (lbs.)
RIGHT HAND PART NO.	LEFT HAND PART NO.	+0.0025 -0.0005	+0.010 -0.010	+0.005 -0.005	+0.005 -0.005	REF.	+0.015 -0.015	UNF 3A	+0.062 -0.031	REF.		
RJM4	RJML4	.2500	.750	.375	.281	.500	1.562	1/4-28	1.000	16	2,168	.04
RJM5	RJML5	.3125	.875	.437	.344	.625	1.875	5/16-24	1.250	14	2,796	.07
RJM6	RJML6	.3750	1.000	.500	.406	.719	1.938	3/8-24	1.250	12	4,012	.11

RJM / RJF  
3-PIECE, PRECISION - CHROME PLATED

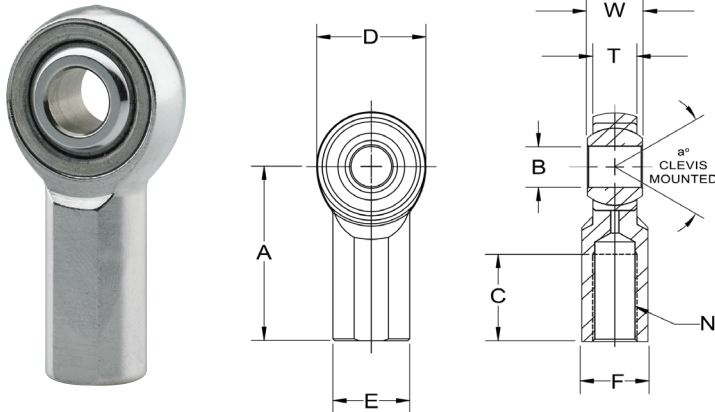

BALL	BODY
52100 STEEL Rc 56 MIN HARD CHROME PLATED	LOW CARBON STEEL DECORATIVE CHROME PLATED
RACE	
STEEL ALLOY - HEAT TREATED ZINC PLATED CHROMATE TREATED	
LINER (OPTIONAL)	
PTFE FABRIC	

FEMALE ROD ENDS		B DIA	D DIA	W WIDTH	T WIDTH	BALL DIA	A LGTH	N THD	C LGTH	E DIA.	F FLAT	a° MIS ANGLE	ULT. STATIC RADIAL LOAD (lbs.)	APPROX. WEIGHT (lbs.)
RIGHT HAND PART NO.	LEFT HAND PART NO.	+0.0025 -0.0005	+0.010 -0.010	+0.005 -0.005	+0.005 -0.005	REF.	+0.015 -0.015	UNF 2B	+0.062 -0.031	+0.010 -0.010	+0.010 -0.010	REF.		
RJF4	RJFL4	.2500	.750	.375	.281	.500	1.312	1/4-28	.687	.468	.375	16	2,545	.06
RJF5	RJFL5	.3125	.875	.437	.344	.625	1.375	5/16-24	.687	.500	.437	14	3,200	.09
RJF6	RJFL6	.3750	1.000	.500	.406	.719	1.625	3/8-24	.812	.687	.562	12	3,950	.15

AVAILABLE OPTIONS	SUFFIX	EXAMPLE
PTFE LINER	T	RJF5T

# RJMX-T / RJMXL-T

3-PIECE, HEAVY DUTY / EXTRA HEAVY DUTY, PTFE LINED

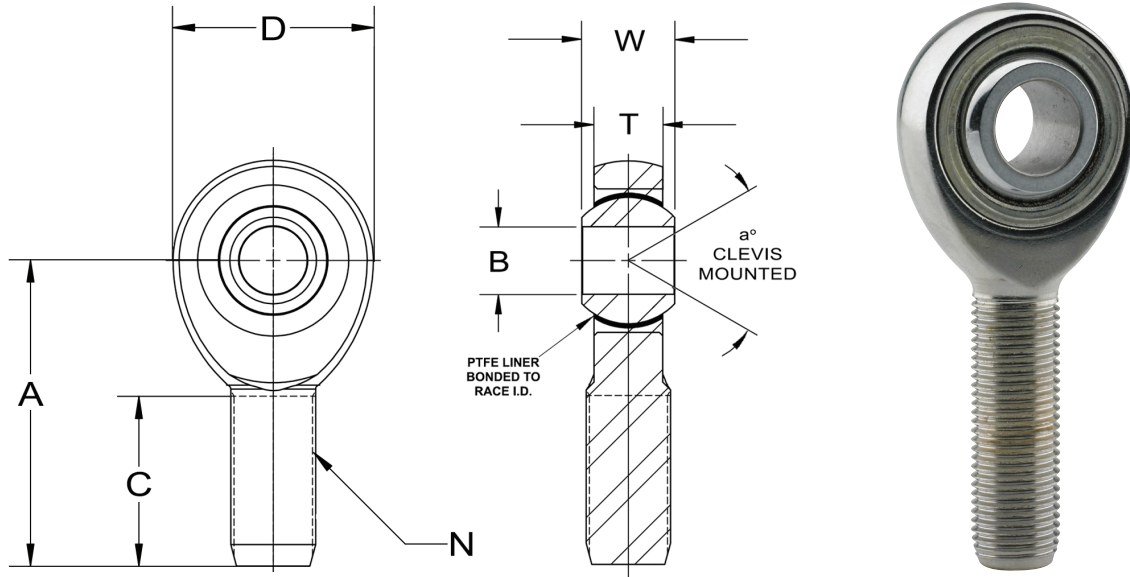

MALE ROD ENDS		B DIA	D DIA	W WIDTH	T WIDTH	BALL DIA	A LGTH	N THD	C LGTH	a° MIS ANGLE	ULT. STATIC RADIAL LOAD (lbs.)	APPROX. WEIGHT (lbs.)
RIGHT HAND PART NO.	LEFT HAND PART NO.											
RJMX5T	RJMXL5T	.3125 +.0025 -.0005	.875 +.010 -.010	.437 +.005 -.005	.344 +.005 -.005	.625 REF.	1.875 +.015 -.015	5/16-24 UNF 3A	1.250 +.062 -.031	14 REF.	7,640	.07
RJMX6T	RJMXL6T	.3750	1.000	.500	.406	.719	1.938	3/8-24	1.250	12	9,550	.112
RJMX7T	RJMXL7T	.4375	1.125	.562	.437	.812	2.125	7/16-20	1.375	14	10,290	.160
RJMX8T	RJMXL8T	.5000	1.312	.625	.500	.937	2.438	1/2-20	1.500	12	16,242	.249
RJMX10T	RJMXL10T	.6250	1.500	.750	.562	1.125	2.625	5/8-18	1.625	16	17,959	.382
RJMX12T	RJMXL12T	.7500	1.750	.875	.687	1.312	2.875	3/4-16	1.750	14	28,090	.602

RJMX-T / RJMXL-T  
3-PIECE, HEAVY DUTY / EXTRA HEAVY DUTY, PTFE LINED

BALL	BODY
52100 STEEL Rc 56 MIN HARD HARD CHROME PLATED	STEEL ALLOY - HEAT TREATED BRIGHT ELECTROLESS NICKEL OR HARD CHROME PLATED
RACE	
STEEL ALLOY - HEAT TREATED ZINC PLATED CHROMATE TREATED	
LINER (STANDARD)	
PTFE FABRIC	

# KMX / KMXL

3-PIECE, ALLOY STEEL, HEAT TREATED - NYLON RACE

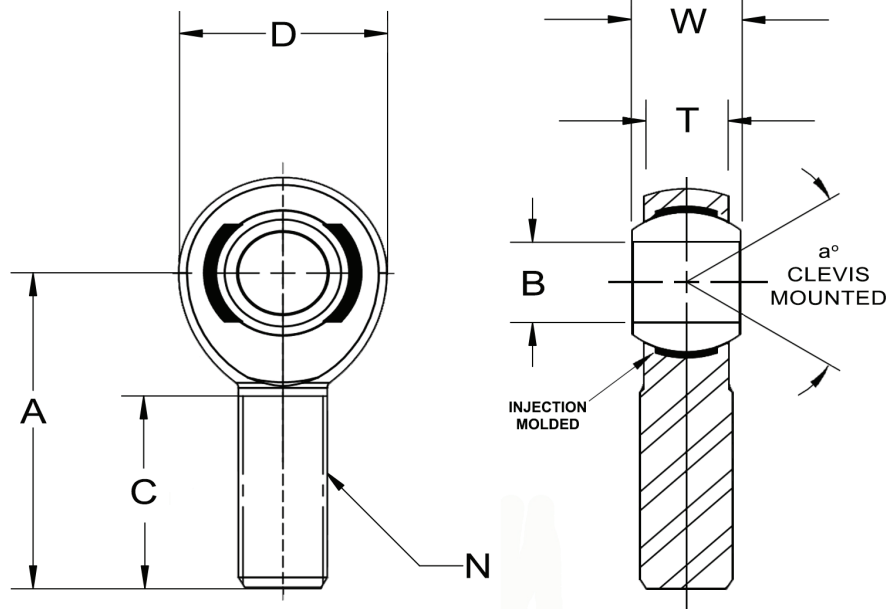

KMX / KMXL  
3-PIECE, ALLOY STEEL, HEAT TREATED - NYLON RACE

MALE ROD ENDS		B DIA	D DIA	W WIDTH	T WIDTH	BALL DIA	A LGTH	N THD	C LGTH	a° MIS ANGLE	ULT. STATIC RADIAL LOAD (lbs.)	APPROX. WEIGHT (lbs.)
RIGHT HAND PART NO.	LEFT HAND PART NO.											
		+0.0025 -0.0005	+0.010 -0.010	+0.005 -0.005	+0.005 -0.005	REF.	+0.015 -0.015	UNF 3A	+0.062 -0.031	REF.		
KMX5	KMXL5	.3125	.875	.437	.344	.625	1.875	5/16-24	1.250	14	7,600	.07
KMX6-5	KMXL6-5	.3125	1.000	.437	.344	.625	1.938	3/8-24	1.250	14	9,500	.11
KMX6	KMXL6	.3750	1.000	.500	.406	.719	1.938	3/8-24	1.250	12	9,500	.11
KMX8	KMXL8	.5000	1.312	.625	.500	.937	2.438	1/2-20	1.500	12	12,696	.24
KMX10-8	KMXL10-8	.5000	1.500	.625	.500	.937	2.625	5/8-18	1.625	12	19,960	.36
KMX10	KMXL10	.6250	1.500	.750	.562	1.125	2.625	5/8-18	1.625	16	14,480	.36
KMX12-8	KMXL12-8	.5000	1.750	.750	.562	1.125	2.875	3/4-16	1.750	14	23,256	.57
KMX12-10	KMXL12-10	.6250	1.750	.750	.562	1.125	2.875	3/4-16	1.750	14	23,256	.57
KMX12	KMXL12	.7500	1.750	.875	.687	1.312	2.875	3/4-16	1.750	14	23,192	.57
KMX14	KMXL14	.8750	2.000	.875	.770	1.375	3.375	7/8-14	2.000	12	45,051	.88
KMX14-12	KMXL14-12	.7500	2.000	.875	.687	1.312	3.375	7/8-14	1.875	12	43,485	.88
KMX16	KMXL16	1.0000	2.750	1.375	1.000	1.875	4.125	1.250-12	2.125	17	76,200	2.41

AVAILABLE OPTIONS	SUFFIX	EXAMPLE
STUD (SEE PG 45 FOR STUD SPECS)	Y	KMX10Y
*AVAILABLE UPON REQUEST		

BALL	BODY
52100 STEEL Rc 56 MIN HARD HARD CHROME PLATED	STEEL ALLOY-HEAT TREATED CHROME PLATED
RACE	
NYLON 10 OR EQUIVALENT	

# SJM-T / SJF-T

3-PIECE, PRECISION - STAINLESS STEEL, HIGH STRENGTH, PTFE LINED

BALL	BODY
400 SERIES STAINLESS STEEL HEAT TREATED	17-4PH CRES STAINLESS STEEL HEAT TREATED
RACE	LINER (STANDARD)
17-4PH CRES STAINLESS STEEL HEAT TREATED	PTFE FABRIC

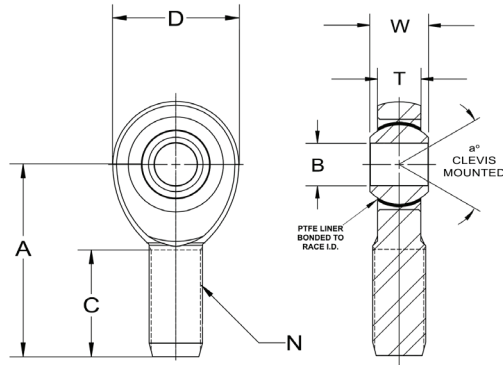

MALE ROD ENDS		B DIA	D DIA	W WIDTH	T WIDTH	BALL DIA	A LGTH	N THD	C LGTH	a° MIS ANGLE	ULT. STATIC RADIAL LOAD (lbs.)	APPROX. WEIGHT (lbs.)
RIGHT HAND PART NO.	LEFT HAND PART NO.											
SJM4T	SJML4T	.2500 -.0005	.806 -.010	.437 -.005	.337 -.005	.531 REF.	1.562 +.015 -.015	1/4-28 UNF 3A	.968 +.062 -.031	11 REF.	4,874	.072
SJM5T	SJML5T	.3125	.900	.437	.344	.625	1.875	5/16-24	1.187	11	7,196	.087
SJM6T	SJML6T	.3750	1.025	.500	.416	.687	1.938	3/8-24	1.187	11	8,580	.136
SJM7T	SJML7T	.4375	1.150	.562	.452	.781	2.125	7/16-20	1.281	13	12,000	.183
SJM8T	SJML8T	.5000	1.337	.625	.515	.875	2.438	1/2-20	1.468	11	19,520	.278
SJM10T	SJML10T	.6250	1.525	.750	.577	1.062	2.625	5/8-18	1.562	14	21,920	.424
SJM12T	SJML12T	.7500	1.775	.875	.640	1.250	2.875	3/4-16	1.687	17	29,310	.639

BALL	BODY
400 SERIES STAINLESS STEEL HEAT TREATED	17-4PH CRES STAINLESS STEEL HEAT TREATED
RACE	LINER (STANDARD)
17-4PH CRES STAINLESS STEEL HEAT TREATED	PTFE FABRIC

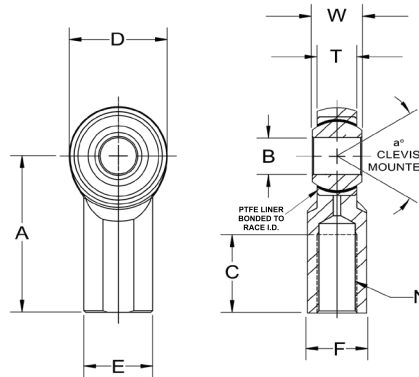

FEMALE ROD ENDS		B DIA	D DIA	W WIDTH	T WIDTH	BALL DIA	A LGTH	N THD	C LGTH	E DIA.	F FLAT	a° MIS ANGLE	ULT. STATIC RADIAL LOAD (lbs.)	APPROX. WEIGHT (lbs.)
RIGHT HAND PART NO.	LEFT HAND PART NO.													
SJF4T	SJFL4T	.2500 -.0005	.806 -.010	.375 -.005	.281 -.005	.500 REF.	1.312 +.015 -.015	1/4-28 UNF 2B	.750 +.062 -.031	.469 +.010 -.010	.375 +.010 -.010	16 REF.	4,795	.059
SJF5T	SJFL5T	.3125	.900	.437	.344	.625	1.375	5/16-24	.750	.500	.437	14	5,929	.092
SJF6T	SJFL6T	.3750	1.025	.500	.406	.719	1.625	3/8-24	.937	.687	.562	12	7,363	.152
SJF7T	SJFL7T	.4375	1.150	.562	.437	.812	1.812	7/16-20	1.062	.750	.625	14	7,934	.198
SJF8T	SJFL8T	.5000	1.337	.625	.500	.937	2.125	1/2-20	1.187	.875	.750	12	12,527	.329
SJF10T	SJFL10T	.6250	1.525	.750	.562	1.125	2.500	5/8-18	1.500	1.000	.875	16	13,851	.477
SJF12T	SJFL12T	.7500	1.775	.875	.687	1.312	2.875	3/4-16	1.750	1.125	1.000	14	21,664	.723

SJM-T / SJF-T  
3-PIECE, PRECISION - STAINLESS STEEL, HIGH STRENGTH, PTFE LINED

# HJMX-T / HRSMX-T / HIN-T

HIGH MISALIGNMENT SERIES - MALE ROD ENDS & SPHERICAL BEARINGS - HEAVY DUTY, PTFE LINED

HJMX-T / HRSMX-T / HIN-T  
HIGH MISALIGNMENT SERIES - HEAVY DUTY

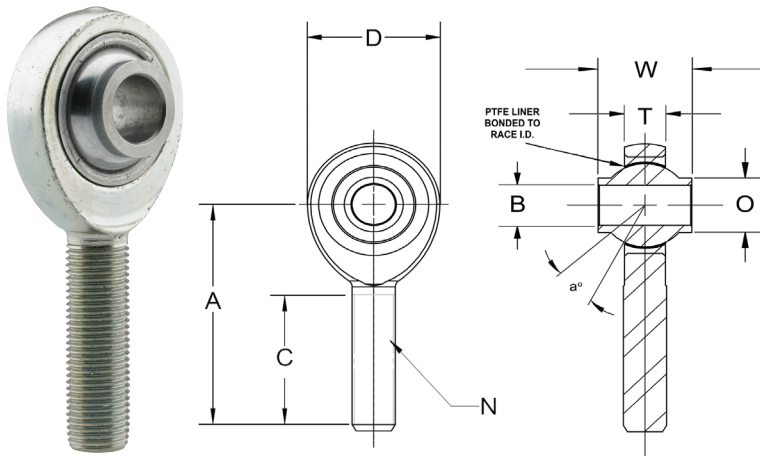

BALL	BODY
52100 STEEL HEAT TREATED HARD CHROME PLATED	4340 STEEL HEAT TREATED ZINC PLATED CHROMATE TREATED
RACE	LINER (STANDARD)
STEEL ALLOY ZINC PLATED CHROMATE TREATED	PTFE FABRIC

MALE ROD ENDS		B DIA	D DIA	W WIDTH	T WIDTH	BALL DIA	A LGTH	N THD	C LGTH	O DIA.	a° MIS ANGLE	ULT. STATIC RADIAL LOAD (lbs.)	APPROX. WEIGHT (lbs.)
RIGHT HAND PART NO.	LEFT HAND PART NO.	+0.0015 -0.0005	+0.010 -0.010	+0.005 -0.005	+0.005 -0.005	REF.	+0.015 -0.015	UNF 3A	+0.062 -0.031	REF.	REF.		
HRSMX4T	HRSMXL4T	.2500	1.025	.593	.265	.593	1.938	3/8-24	1.187	.390	23	10,790	.12
HRSMX5T	HRSMXL5T	.3125	1.150	.813	.355	.781	2.125	7/16-20	1.281	.512	22	11,789	.16
HJMX6T	HJMXL6T	.3750	1.150	.813	.355	.781	2.125	3/8-24	1.281	.512	22	11,390	.12
HRSMX6T	HRSMXL6T	.3750	1.150	.813	.355	.781	2.125	7/16-20	1.281	.512	22	11,789	.15
HJMX7T	HJMXL7T	.4375	1.337	.875	.355	.875	2.438	7/16-20	1.468	.618	21	15,716	.23
HRSMX7T	HRSMXL7T	.4375	1.337	.875	.355	.875	2.438	1/2-20	1.468	.618	21	17,100	.24
HJMX8T	HJMXL8T	.5000	1.525	.937	.411	1.000	2.625	1/2-20	1.562	.730	19	23,703	.33
HRSMX8T	HRSMXL8T	.5000	1.525	.937	.411	1.000	2.625	5/8-18	1.562	.730	19	23,703	.39
HJMX10T	HJMXL10T	.6250	1.775	1.200	.577	1.250	2.875	5/8-18	1.687	.856	19	28,109	.57
HRSMX10T	HRSMXL10T	.6250	1.775	1.200	.577	1.250	2.875	3/4-16	1.687	.856	19	32,100	.60
HJMX12T	HJMXL12T	.7500	2.025	1.280	.630	1.375	3.375	3/4-16	2.000	.970	18	38,701	.82
HRSMX12T	HRSMXL12T	.7500	2.025	1.280	.630	1.375	3.375	7/8-14	2.000	.970	18	38,701	.89

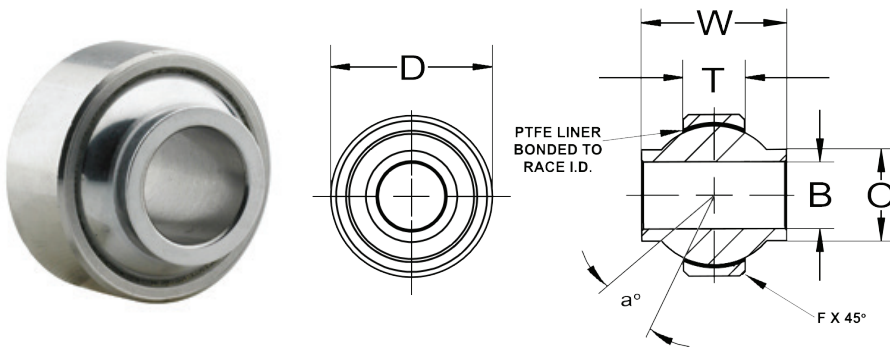

BEARING PART NO.	B DIA	D DIA	W WIDTH	T WIDTH	O DIA.	BALL DIA	F CHAMFER	a° MIS ANGLE	ULT. STATIC RADIAL LOAD (lbs.)	APPROX. WEIGHT (lbs.)
	+0.0015 -0.0005	+0.0000 -0.0005	+0.005 -0.005	+0.005 -0.005	REF.	REF.	REF.	REF.		
HIN4T	.2500	.7400	.593	.255	.390	.593	.020	24	7,560	.040
HIN5T	.3125	.9060	.813	.345	.512	.781	.030	23	16,983	.080
HIN6T	.3750	.9060	.813	.345	.512	.781	.030	23	16,983	.068
HIN7T	.4375	1.0000	.875	.345	.618	.875	.030	22	19,023	.095
HIN8T	.5000	1.1250	.937	.401	.730	1.000	.030	20	25,275	.160
HIN10T	.6250	1.3750	1.200	.567	.856	1.250	.030	20	44,652	.245
HIN12T	.7500	1.5625	1.280	.620	.970	1.375	.035	18	53,716	.315

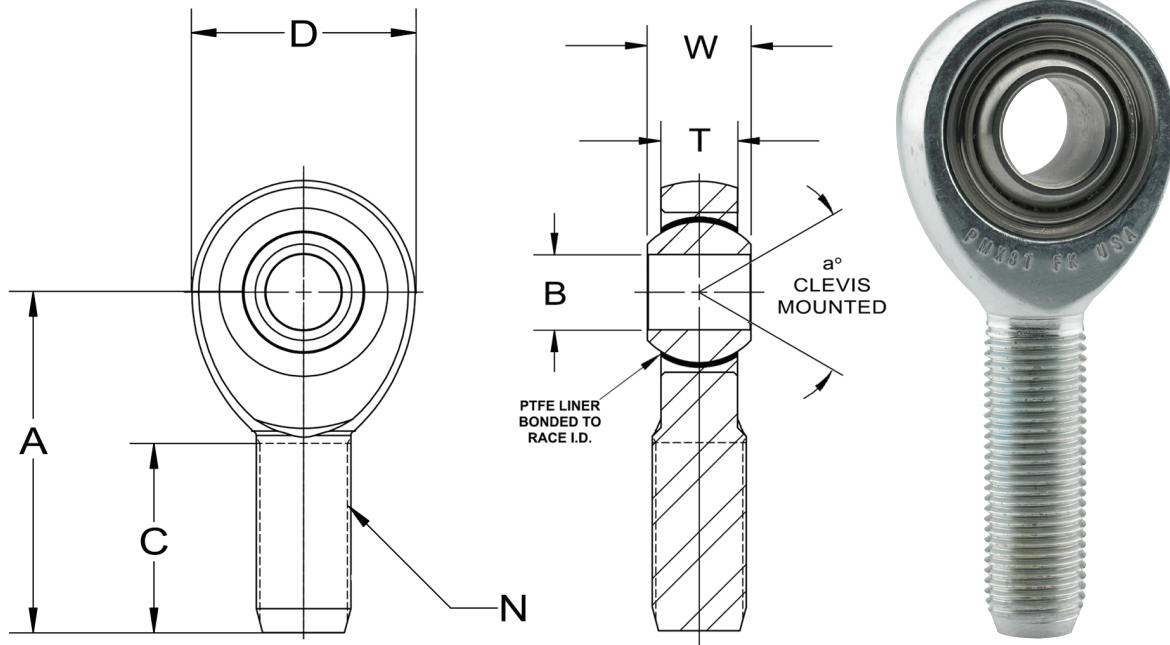

MALE ROD ENDS		B DIA	D DIA	W WIDTH	T WIDTH	BALL DIA	A LGTH	N THD	C LGTH	a° MIS ANGLE	ULT. STATIC RADIAL LOAD (lbs.)	APPROX. WEIGHT (lbs.)
RIGHT HAND PART NO.	LEFT HAND PART NO.											
		+0.0015 -0.0005	+0.010 -0.010	+0.000 -0.005	+0.005 -0.005	REF.	+0.010 -0.010	UNF 3A	+0.031 -0.031	REF.		
PMX5T	PMXL5T	.3125	.900	.437	.327	.593	1.875	5/16-24	1.187	14	8,302	.08
PMX6T	PMXL6T	.3750	1.025	.500	.416	.687	1.938	3/8-24	1.187	8	10,940	.13
PMX7T	PMXL7T	.4375	1.150	.562	.452	.781	2.125	7/16-20	1.281	10	14,052	.18
PMX8T	PMXL8T	.5000	1.337	.625	.515	.875	2.438	1/2-20	1.468	9	23,314	.27
PMX10T	PMXL10T	.6250	1.525	.750	.577	1.062	2.625	5/8-18	1.562	12	25,900	.42
PMX12T	PMXL12T	.7500	1.775	.875	.640	1.250	2.875	3/4-16	1.687	13	34,322	.63

BALL (MANUFACTURER'S OPTION)	BODY
400 SERIES STAINLESS STEEL OR 52100 STEEL (MFR OPTION) HEAT TREATED R/C 56 MIN. HARD CHROME PLATED	4340 STEEL HEAT TREATED ZINC PLATED CHROMATE TREATED
RACE	LINER (STANDARD)
17-4PH STAINLESS STEEL HEAT TREATED	PTFE FABRIC

**PMX-T / PMXL-T**  
 3-PIECE, PERFORMANCE RACING, STAINLESS STEEL RACE, PTFE LINED

# ALJM / ALJM-H / ALJF

3-PIECE, ALUMINUM SERIES / PTFE LINERS AVAILABLE

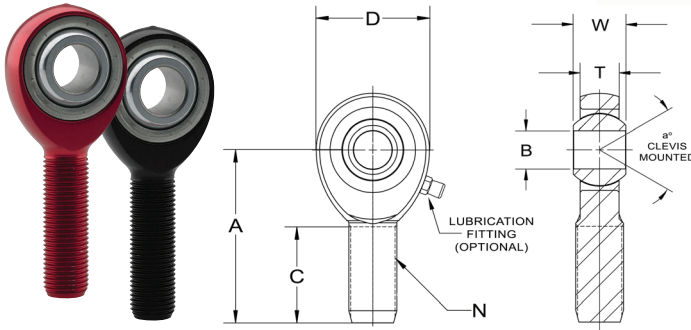

BALL	BODY
52100 STEEL HEAT TREATED HARD CHROME PLATED	ALUMINUM 7075-T6 HARD ANODIZED RED
RACE	
STEEL ALLOY - HEAT TREATED ZINC PLATED - CHROMATE TREATED	
LINER (OPTIONAL)	
PTFE FABRIC	

MALE ROD ENDS		B DIA	D DIA	W WIDTH	T WIDTH	BALL DIA	A LGTH	N THD	C LGTH	a° MIS ANGLE	ULT. STATIC RADIAL LOAD (lbs.)	APPROX. WEIGHT (lbs.)
RIGHT HAND PART NO.	LEFT HAND PART NO.	+0.015 -0.005	+0.010 -0.010	+0.000 -0.005	+0.005 -0.005	REF.	+0.015 -0.015	UNF 3A	+0.062 -0.031	REF.		
ALJM3	ALJML3	.1900	.625	.312	.250	.437	1.250	10-32	.750	13	1,360	.022
ALJM4	ALJML4	.2500	.750	.375	.281	.500	1.562	1/4-28	1.000	16	2,465	.034
ALJM5	ALJML5	.3125	.875	.437	.344	.625	1.875	5/16-24	1.250	14	2,850	.050
ALJM6 <sup>(1)</sup>	ALJML6 <sup>(1)</sup>	.3750	1.000	.500	.406	.719	1.938	3/8-24	1.250	12	4,208	.078
ALJM7	ALJML7	.4375	1.125	.562	.437	.812	2.125	7/16-20	1.375	14	4,534	.091
ALJM8 <sup>(1)</sup>	ALJML8 <sup>(1)</sup>	.5000	1.312	.625	.500	.937	2.438	1/2-20	1.500	12	7,698	.140
ALJM8-6 <sup>(1)</sup>	ALJML8-6 <sup>(1)</sup>	.3750	1.312	.625	.500	.937	2.438	1/2-20	1.500	12	7,698	.140
ALJM10	ALJML10	.6250	1.500	.750	.562	1.125	2.625	5/8-18	1.625	16	8,516	.240
ALJM10H <sup>(2)</sup>	ALJML10H <sup>(2)</sup>	.6250	1.750	.750	.562	1.125	2.625	5/8-18	1.625	16	16,200	.268
ALJM12	ALJML12	.7500	1.750	.875	.687	1.312	2.875	3/4-16	1.750	14	13,319	.300
ALJM12H <sup>(2)</sup>	ALJML12H <sup>(2)</sup>	.7500	2.000	.875	.687	1.312	3.000	3/4-16	1.750	14	23,390	.300

MALE ROD END LOAD RATINGS BASED ON NO LUBRICATION FITTING. FOR LOAD RATINGS WITH LUBRICATOR, PLEASE CONTACT THE FK ENGINEERING DEPARTMENT.

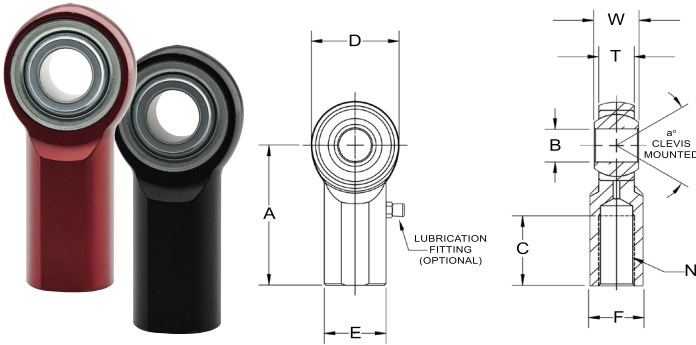

BALL	BODY
52100 STEEL HEAT TREATED HARD CHROME PLATED	ALUMINUM 7075-T6 HARD ANODIZED RED
RACE	
STEEL ALLOY - HEAT TREATED ZINC PLATED - CHROMATE TREATED	
LINER (OPTIONAL)	
PTFE FABRIC	

FEMALE ROD ENDS		B DIA	D DIA	W WIDTH	T WIDTH	BALL DIA	A LGTH	N THD	C LGTH	E DIA.	F FLAT	a° MIS ANGLE	ULT. STATIC RADIAL LOAD (lbs.)	APPROX. WEIGHT (lbs.)
RIGHT HAND PART NO.	LEFT HAND PART NO.	+0.015 -0.005	+0.010 -0.010	+0.000 -0.005	+0.015 -0.015	REF.	+0.015 -0.015	UNF 2B	+0.062 -0.031	+0.010 -0.010	+0.010 -0.010	REF.		
ALJF3 <sup>(1)</sup>	ALJFL3 <sup>(1)</sup>	.1900	.625	.312	.250	.437	1.062	10-32	.500	.406	.312	13	1,360	.022
ALJF4	ALJFL4	.2500	.750	.375	.281	.500	1.312	1/4-28	.687	.469	.375	16	2,592	.034
ALJF5 <sup>(1)</sup>	ALJFL5 <sup>(1)</sup>	.3125	.875	.437	.344	.625	1.375	5/16-24	.687	.500	.437	14	2,890	.050
ALJF6 <sup>(1)</sup>	ALJFL6 <sup>(1)</sup>	.3750	1.000	.500	.406	.719	1.625	3/8-24	.812	.687	.562	12	3,952	.088
ALJF8 <sup>(1)</sup>	ALJFL8 <sup>(1)</sup>	.5000	1.312	.625	.500	.937	2.125	1/2-20	1.062	.875	.750	12	7,006	.186

<sup>(1)</sup> ALSO AVAILABLE IN BLACK ~ ADD "-B" TO SUFFIX

<sup>(2)</sup> CHECK FOR AVAILABILITY

AVAILABLE OPTIONS	SUFFIX	EXAMPLE
PTFE LINER	T	ALJM10T
GREASE FITTING	Z	ALJM10Z
STUD (SEE PG 45 FOR STUD SPECS)	Y	ALJM10Y

# ALRSM / ALRSM L

3-PIECE, ALUMINUM SERIES, EXTRA STRENGTH - HEAVY DUTY SHANK / PTFE LINERS AVAILABLE

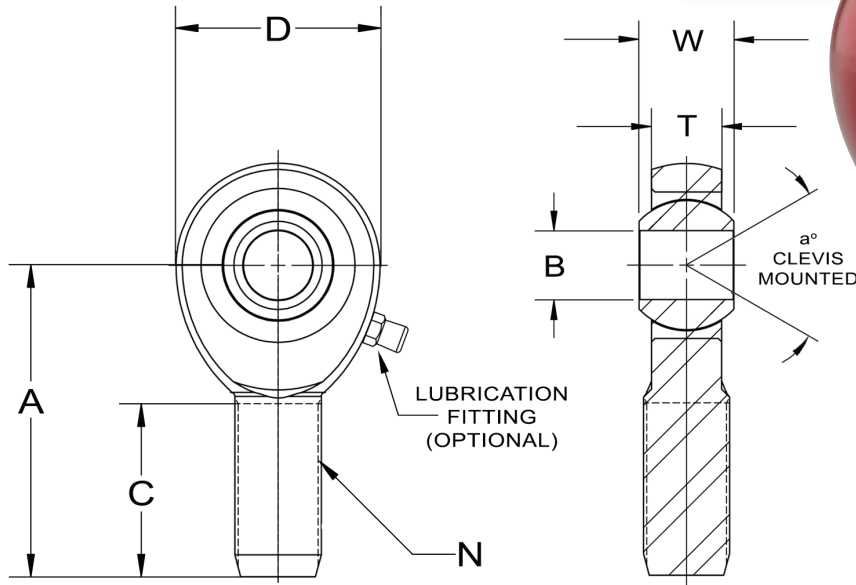

**ALRSM / ALRSM L**  
3-PIECE, ALUMINUM SERIES, EXTRA STRENGTH - HEAVY DUTY SHANK

MALE ROD ENDS		B DIA	D DIA	W WIDTH	T WIDTH	BALL DIA	A LGTH	N THD	C LGTH	a° MIS ANGLE	ULT. STATIC RADIAL LOAD (lbs.)	APPROX. WEIGHT (lbs.)
RIGHT HAND PART NO.	LEFT HAND PART NO.											
ALRSM5	ALRSM L5	+0.015 -.0005	+0.010 -.010	+0.000 -.005	+0.005 -.005	REF.	+0.015 -.015	UNF 3A	+0.062 -.031	REF.	5,592	.059
ALRSM6	ALRSM L6	.3750	1.125	.500	.406	.719	2.125	7/16-20	1.375	10	7,718	.088
ALRSM7	ALRSM L7	.4375	1.312	.562	.437	.812	2.438	1/2-20	1.500	12	11,000	.121
ALRSM8 <sup>(1)</sup>	ALRSM L8 <sup>(1)</sup>	.5000	1.500	.625	.500	.937	2.625	5/8-18	1.625	10	14,880	.200
ALRSM8-6 <sup>(1)</sup>	ALRSM L8-6 <sup>(1)</sup>	.3750	1.500	.625	.500	.937	2.625	5/8-18	1.625	10	14,880	.200
ALRSM10	ALRSM L10	.6250	1.750	.750	.562	1.125	2.875	3/4-16	1.750	13	19,240	.317
ALRSM10-8	ALRSM L10-8	.5000	1.750	.750	.562	1.125	2.875	3/4-16	1.750	13	19,240	.317

<sup>(1)</sup> ALSO AVAILABLE IN BLACK ~ ADD "-B" TO SUFFIX

BALL	BODY
52100 STEEL HEAT TREATED HARD CHROME PLATED	ALUMINUM 7075-T6 HARD ANODIZED RED
RACE	
STEEL ALLOY - HEAT TREATED ZINC PLATED - CHROMATE TREATED	
LINER (OPTIONAL)	
PTFE FABRIC	

AVAILABLE OPTIONS	SUFFIX	EXAMPLE
PTFE LINER	T	ALRSM10T
GREASE FITTING	Z	ALRSM10Z
STUD (SEE PG 45 FOR STUD SPECS)	Y	ALRSM10Y

# RSM / RSMX

3-PIECE, HIGH STRENGTH - HEAVY DUTY SHANK / PTFE LINERS AVAILABLE

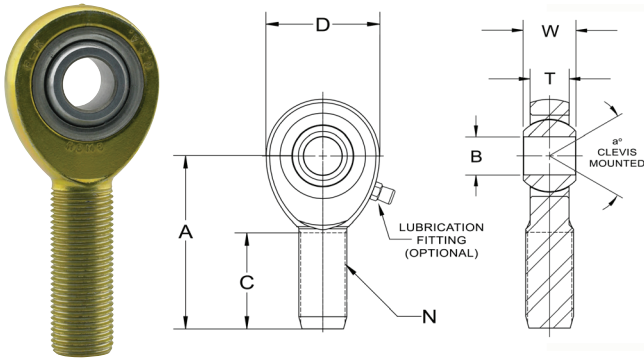

BALL	BODY
52100 STEEL Rc 56 MIN HARD HARD CHROME PLATED	LOW CARBON STEEL ZINC PLATED CHROMATE TREATED
RACE	
STEEL ALLOY - HEAT TREATED ZINC PLATED CHROMATE TREATED	
LINER (OPTIONAL)	
PTFE FABRIC	

MALE ROD ENDS		B DIA	D DIA	W WIDTH	T WIDTH	BALL DIA	A LGTH	N THD	C LGTH	a° MIS ANGLE	ULT. STATIC RADIAL LOAD (lbs.)	APPROX. WEIGHT (lbs.)
RIGHT HAND PART NO.	LEFT HAND PART NO.	+0.015 -0.005	+0.010 -0.010	+0.005 -0.005	+0.005 -0.005	REF.	+0.015 -0.015	UNF 3A	+0.062 -0.031	REF.		
RSM3	RSML3	.1900	.750	.312	.250	.437	1.562	1/4-28	1.000	10	2,170	.043
RSM4	RSML4	.2500	.875	.375	.281	.500	1.875	5/16-24	1.250	13	3,523	.072
RSM5	RSML5	.3125	1.000	.437	.344	.625	1.938	3/8-24	1.250	12	5,370	.112
RSM6	RSML6	.3750	1.125	.500	.406	.719	2.125	7/16-20	1.375	10	7,230	.160
RSM7	RSML7	.4375	1.312	.562	.437	.812	2.438	1/2-20	1.500	12	9,685	.249
RSM8	RSML8	.5000	1.500	.625	.500	.937	2.625	5/8-18	1.625	10	12,843	.382
RSM10	RSML10	.6250	1.750	.750	.562	1.125	2.875	3/4-16	1.750	13	16,613	.602

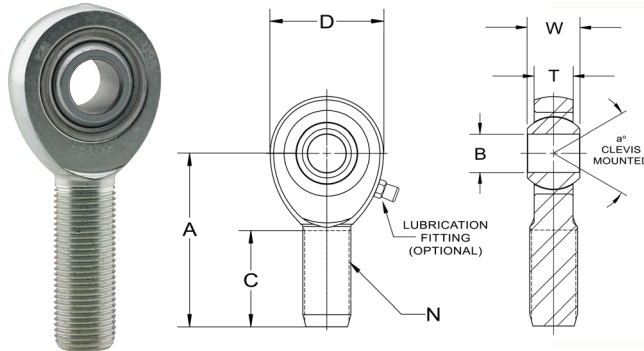

BALL	BODY
52100 STEEL Rc 56 MIN HARD HARD CHROME PLATED	STEEL ALLOY-HEAT TREATED ZINC PLATED CHROMATE TREATED
RACE	
STEEL ALLOY - HEAT TREATED ZINC PLATED CHROMATE TREATED	
LINER (OPTIONAL)	
PTFE FABRIC	

MALE ROD ENDS		B DIA	D DIA	W WIDTH	T WIDTH	BALL DIA	A LGTH	N THD	C LGTH	a° MIS ANGLE	ULT. STATIC RADIAL LOAD (lbs.)	APPROX. WEIGHT (lbs.)
RIGHT HAND PART NO.	LEFT HAND PART NO.	+0.015 -0.005	+0.010 -0.010	+0.005 -0.005	+0.005 -0.005	REF.	+0.015 -0.015	UNF 3A	+0.062 -0.031	REF.		
RSMX4	RSMXL4	.2500	.875	.375	.281	.500	1.875	5/16-24	1.250	13	8,471	.072
RSMX5	RSMXL5	.3125	1.000	.437	.344	.625	1.938	3/8-24	1.250	12	13,012	.112
RSMX6	RSMXL6	.3750	1.125	.500	.406	.719	2.125	7/16-20	1.375	10	17,610	.160
RSMX7	RSMXL7	.4375	1.312	.562	.437	.812	2.438	1/2-20	1.500	12	23,470	.249
RSMX8	RSMXL8	.5000	1.500	.625	.500	.937	2.625	5/8-18	1.625	10	31,420	.382
RSMX10-8	RSMXL10-8	.5000	1.750	.750	.562	1.125	2.875	3/4-16	1.750	13	40,590	.602
RSMX10	RSMXL10	.6250	1.750	.750	.562	1.125	2.875	3/4-16	1.750	13	40,590	.602
RSMX12	RSMXL12	.7500	2.000	.875	.687	1.312	3.375	7/8-14	1.875	12	55,696	.918
RSMX14T <sup>(1)</sup>	RSMXL14T <sup>(1)</sup>	.8750	2.312	.875	.765	1.375	3.800	1-14	2.375	12	63,096	1.302

\* MALE ROD END LOAD RATINGS BASED ON NO LUBRICATION FITTING. FOR LOAD RATINGS WITH LUBRICATOR, PLEASE CONTACT THE FK ENGINEERING DEPARTMENT.

<sup>(1)</sup> RACE IS 17-4PH STAINLESS STEEL, HEAT TREATED / BALL IS 440C STAINLESS STEEL OR 52100 STEEL (HEAT TREATED) - MANUFACTURER'S OPTION

AVAILABLE OPTIONS	SUFFIX	EXAMPLE
PTFE LINER	T	RSMX10T
GREASE FITTING	Z	RSMX10Z
STUD (SEE PG 45 FOR STUD SPECS)	Y	RSMX10Y

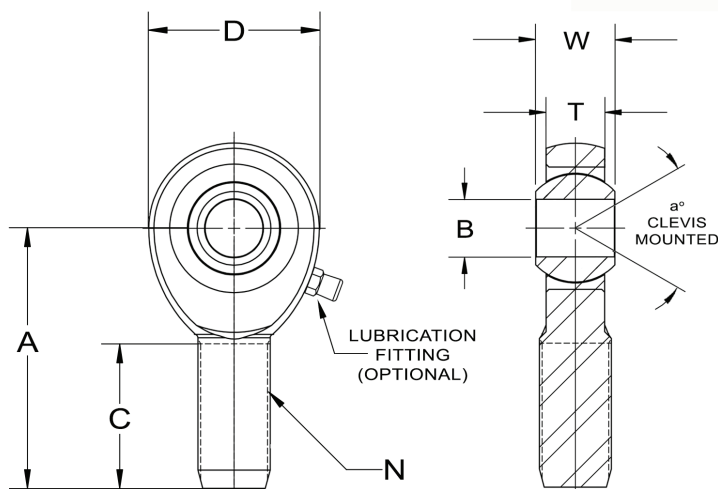

**EMX**  
3-PIECE, PRECISION - EXTRA CAPACITY

MALE ROD ENDS		B DIA	D DIA	W WIDTH	T WIDTH	BALL DIA	A LGTH	N THD	C LGTH	a° MIS ANGLE	ULT. STATIC RADIAL LOAD (lbs.)		APPROX. WEIGHT (lbs.)
RIGHT HAND PART NO.	LEFT HAND PART NO.										WITH LUBE	WITHOUT LUBE	
EMX4	EMXL4	.2500	.750	.375	.281	.500	1.562	5/16-24	1.000	16	3,260	6,680	.06
EMX5	EMXL5	.3125	.875	.437	.344	.625	1.875	3/8-24	1.250	14	4,920	8,410	.09
EMX6	EMXL6	.3750	1.000	.500	.406	.719	1.938	7/16-20	1.250	12	7,240	11,160	.13
EMX7	EMXL7	.4375	1.125	.562	.437	.812	2.125	1/2-20	1.375	14	7,620	13,660	.18
EMX8	EMXL8	.5000	1.312	.625	.500	.937	2.438	5/8-18	1.500	12	11,920	19,340	.30
EMX10	EMXL10	.6250	1.500	.750	.562	1.125	2.625	3/4-16	1.625	16	13,940	21,080	.46
EMX12	EMXL12	.7500	1.750	.875	.687	1.312	2.875	7/8-14	1.750	14	21,570	29,800	.72

BALL	BODY
52100 STEEL Rc 56 MIN HARD HARD CHROME PLATED	STEEL ALLOY-HEAT TREATED ZINC PLATED CHROMATE TREATED
RACE	STEEL ALLOY - HEAT TREATED ZINC PLATED CHROMATE TREATED
LINER (OPTIONAL)	PTFE FABRIC

AVAILABLE OPTIONS	SUFFIX	EXAMPLE
PTFE LINER	T	EMX10T
GREASE FITTING	Z	EMX10Z
STUD (SEE PG 45 FOR STUD SPECS)	Y	EMX10Y

# CM-M / CF-M

2-PIECE METRIC, METAL TO METAL / PTFE LINERS AVAILABLE

# METRIC

METRIC

CM-M / CF-M  
2-PIECE METRIC, METAL TO METAL

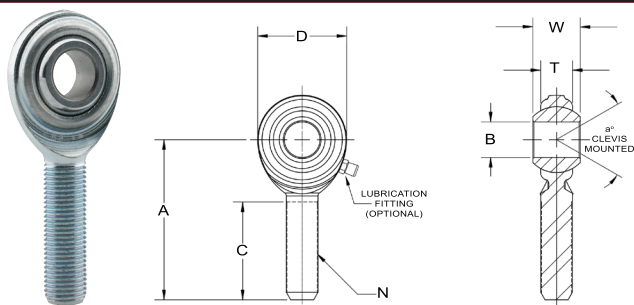

BALL	BODY
52100 STEEL Rc 56 MIN HARD CHROME PLATED	LOW CARBON STEEL ZINC PLATED CHROMATE TREATED
<b>LINER (OPTIONAL)</b>	
PTFE FABRIC	

MALE ROD ENDS		B DIA	D DIA	W WIDTH	T WIDTH	BALL DIA	A LGTH	N THD	C LGTH	a° MIS ANGLE	ULT. STATIC RADIAL LOAD Newton	APPROX. WEIGHT (GRAMS)
RIGHT HAND PART NO.	LEFT HAND PART NO.	+0.065 -0.013	+0.38 -0.38	+0.13 -0.13	REF.	REF.	+0.40 -0.40	MM	+1.00 -1.00	REF.		
CM5M <sup>(1)</sup>	CML5M <sup>(1)</sup>	5	16	8	5.75	11.10	33	M5 X 0.8	20	22	5,168	12
CM6M <sup>(1)</sup>	CML6M <sup>(1)</sup>	6	19	9	6.25	12.70	36	M6 X 1.0	22	23	7,296	18
CM8M <sup>(1)</sup>	CML8M <sup>(1)</sup>	8	22.25	12	8.0	15.88	42	M8 X 1.25	25	28	13,591	31
CM10M	CML10M	10	27	14	9.5	19.05	48	M10 X 1.5	29	26	21,024	68
CM10MF	CML10MF	10	27	14	9.5	19.05	48	M10 X 1.25	29	26	21,024	68
CM12M	CML12M	12	30	16	10.75	22.23	54	M12 X 1.75	33	27	25,819	78
CM12MF	CML12MF	12	30	16	10.75	22.23	54	M12 X 1.25	33	27	25,819	78
CM14M	CML14M	14	34.75	19	12.25	25.40	60	M14 X 2.0	36	30	35,214	118
CM16M	CML16M	16	38	21	12.75	28.58	66	M16 X 2.0	40	33	37,391	173
CM18M	CML18M	18	42	23	14.75	31.75	72	M18 X 1.5	44	30	47,903	260
CM20M	CML20M	20	46	25	16.25	34.93	78	M20 X 1.5	47	29	57,101	290

\* MALE ROD END LOAD RATINGS BASED ON NO LUBRICATION FITTING. FOR LOAD RATINGS WITH LUBRICATOR, PLEASE CONTACT THE FK ENGINEERING DEPARTMENT.

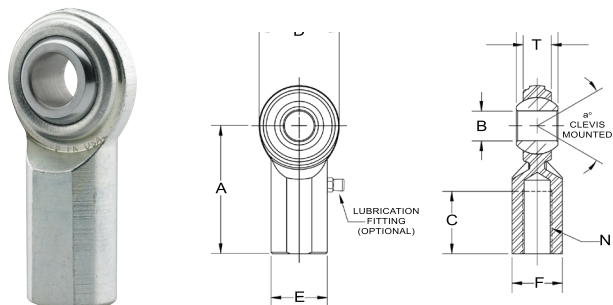

BALL	BODY
52100 STEEL Rc 56 MIN HARD CHROME PLATED	LOW CARBON STEEL ZINC PLATED CHROMATE TREATED
<b>LINER (OPTIONAL)</b>	
PTFE FABRIC	

FEMALE ROD ENDS		B DIA	D DIA	W WIDTH	T WIDTH	BALL DIA	A LGTH	N THD	C LGTH	E DIA.	F FLAT	a° MIS ANGLE	ULT. STATIC RADIAL LOAD Newton	APPROX. WEIGHT (GRAMS)
RIGHT HAND PART NO.	LEFT HAND PART NO.	+0.065 -0.013	+0.38 -0.38	+0.13 -0.13	REF.	REF.	+0.40 -0.40	MM	+1.00 -1.00	+0.25 -0.25	+0.25 -0.25	REF.		
CF5M <sup>(1)</sup>	CFL5M <sup>(1)</sup>	5	16	8	5.75	11.10	27	M5 X 0.8	14	11	9	22	8,247	18
CF6M	CFL6M	6	19	9	6.25	12.70	30	M6 X 1.0	14	13	11	23	11,895	25
CF8M	CFL8M	8	22.25	12	8.0	15.88	36	M8 X 1.25	17	16	14	28	15,190	40
CF10M	CFL10M	10	27	14	9.5	19.05	43	M10 X 1.5	21	19	17	26	22,750	80
CF10MF	CFL10MF	10	27	14	9.5	19.05	43	M10 X 1.25	21	19	17	26	22,750	80
CF12M	CFL12M	12	30	16	10.75	22.23	50	M12 X 1.75	24	22	19	27	25,819	95
CF12MF	CFL12MF	12	30	16	10.75	22.23	50	M12 X 1.25	24	22	19	27	25,819	95
CF14M	CFL14M	14	34.75	19	12.25	25.40	57	M14 X 2.0	27	25	22	30	35,214	160
CF16M	CFL16M	16	38	21	12.75	28.58	64	M16 X 2.0	33	27	22	33	37,391	215
CF18M	CFL18M	18	42	23	14.75	31.75	71	M18 X 1.5	36	28.58	25.4	30	47,903	300
CF20M	CFL20M	20	46	25	16.25	34.93	77	M20 X 1.5	40	30.15	27	29	57,101	350

AVAILABLE OPTIONS	SUFFIX	EXAMPLE
PTFE LINER	T	CM10MT
GREASE FITTING	Z	CM10MZ
STUD (SEE PG 45 FOR STUD SPECS)	Y	CM10MY

<sup>(1)</sup> GREASE FITTINGS ARE NOT AVAILABLE ON THESE SIZES

BALL		BODY	
400 SERIES STAINLESS STEEL HEAT TREATED		303 STAINLESS STEEL	
LINER (STANDARD)			
PTFE FABRIC			

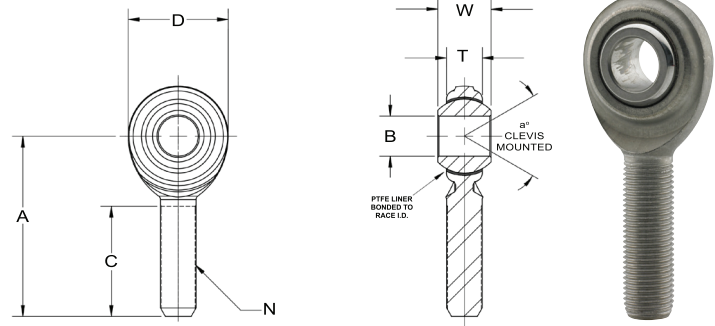

MALE ROD ENDS		B DIA	D DIA	W WIDTH	T WIDTH	BALL DIA	A LGTH	N THD	C LGTH	a° MIS ANGLE	ULT. STATIC RADIAL LOAD Newton	APPROX. WEIGHT (GRAMS)
RIGHT HAND PART NO.	LEFT HAND PART NO.	+0.065 -.013	+0.38 -.38	+0.13 -.13	REF.	REF.	+0.40 -.40	MM	+1.00 -1.00	REF.		
SCM5MT	SCML5MT	5	16	8	5.75	11.10	33	M5 X 0.8	20	22	4,056	12
SCM6MT	SCML6MT	6	19	9	6.25	12.70	36	M6 X 1.0	22	23	6,093	18
SCM8MT	SCML8MT	8	22.25	12	8.0	15.88	42	M8 X 1.25	25	28	9,118	31
SCM10MT	SCML10MT	10	27	14	9.5	19.05	48	M10 X 1.5	29	26	14,144	68
SCM12MT	SCML12MT	12	30	16	10.75	22.23	54	M12 X 1.75	33	27	17,373	78
SCM14MT	SCML14MT	14	34.75	19	12.25	25.40	60	M14 X 2.0	36	30	23,699	118
SCM16MT	SCML16MT	16	38	21	12.75	28.58	66	M16 X 2.0	40	33	25,162	173
SCM18MT	SCML18MT	18	42	23	14.75	31.75	72	M18 X 1.5	44	30	28,589	260
SCM20MT	SCML20MT	20	46	25	16.25	34.93	78	M20 X 1.5	47	29	34,245	290

BALL		BODY	
440 SERIES STAINLESS STEEL HEAT TREATED		303 STAINLESS STEEL	
LINER (STANDARD)			
PTFE FABRIC			

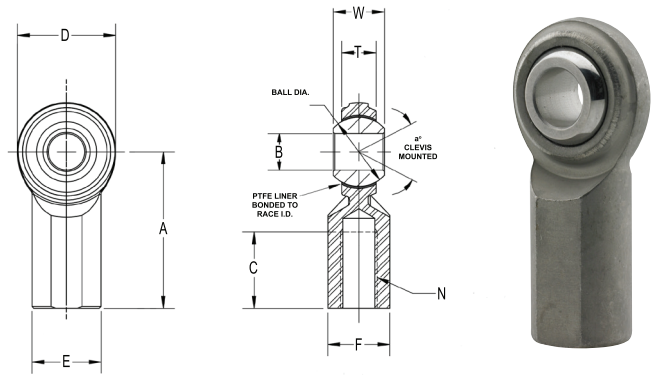

FEMALE ROD ENDS		B DIA	D DIA	W WIDTH	T WIDTH	BALL DIA	A LGTH	N THD	C LGTH	E DIA.	F FLAT	a° MIS ANGLE	ULT. STATIC RADIAL LOAD Newton	APPROX. WEIGHT (GRAMS)
RIGHT HAND PART NO.	LEFT HAND PART NO.	+0.065 -.013	+0.38 -.38	+0.13 -.13	REF.	REF.	+0.40 -.40	MM	+1.00 -1.00	+0.25 -.25	+0.25 -.25	REF.		
SCF5MT	SCFL5MT	5	16	8	5.75	11.10	27	M5 X 0.8	14	11	9	22	4,136	18
SCF6MT	SCFL6MT	6	19	9	6.25	12.70	30	M6 X 1.0	14	13	11	23	6,138	25
SCF8MT	SCFL8MT	8	22.25	12	8.0	15.88	36	M8 X 1.25	17	16	14	28	9,340	40
SCF10MT	SCFL10MT	10	27	14	9.5	19.05	43	M10 X 1.5	21	19	17	26	15,310	80
SCF12MT	SCFL12MT	12	30	16	10.75	22.23	50	M12 X 1.75	24	22	19	27	17,373	95
SCF14MT	SCFL14MT	14	34.75	19	12.25	25.40	57	M14 X 2.0	27	25	22	30	23,699	160
SCF16MT	SCFL16MT	16	38	21	12.75	28.58	64	M16 X 2.0	33	27	22	33	25,162	215
SCF18MT	SCFL18MT	18	42	23	14.75	31.75	71	M18 X 1.5	36	28.58	25.4	30	28,589	300
SCF20MT	SCFL20MT	20	46	25	16.25	34.93	77	M20 X 1.5	40	30.15	27	29	34,245	350

SCM-MT / SCF-MT  
2-PIECE METRIC, STAINLESS STEEL, PTFE LINED  
METRIC

# JM-M / JML-M

3-PIECE MALE METRIC, PRECISION - WEAR RESISTANT / PTFE LINERS AVAILABLE

# METRIC

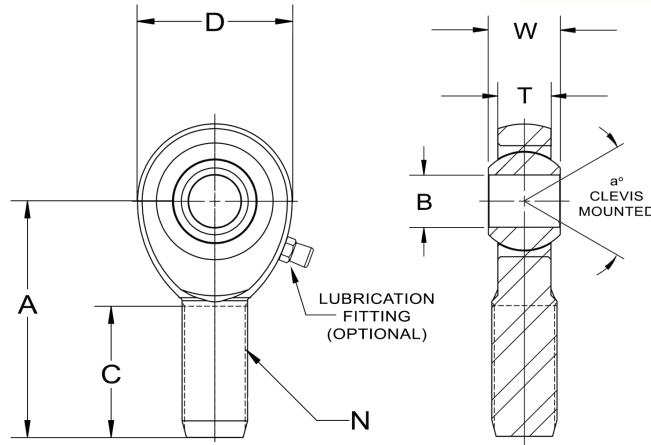

**JM-M / JML-M**  
3-PIECE MALE METRIC, PRECISION

MALE ROD ENDS		B DIA	D DIA	W WIDTH	T WIDTH	BALL DIA	A LGTH	N THD	C LGTH	a° MIS ANGLE	ULT. STATIC RADIAL LOAD Newton	APPROX. WEIGHT (GRAMS)
RIGHT HAND PART NO.	LEFT HAND PART NO.	+0.065 -0.013	+0.38 -0.38	+0.13 -0.13	+0.13 -0.13	REF.	+0.40 -0.40	MM	+1.00 -1.00	REF.		
JM5M	JML5M	5	16	8	6.25	11.10	33	M5 X 0.8	20	14	5,170	13
JM6M	JML6M	6	19	9	7	12.70	36	M6 X 1.0	22	13	7,295	18
JM8MF	JML8MF	8	22.25	12	8.75	15.88	42	M8 X 1.0	25	18	13,595	31
JM8M	JML8M	8	22.25	12	8.75	15.88	42	M8 X 1.25	25	18	13,595	31
JM10MF	JML10MF	10	27	14	10.5	19.05	48	M10 X 1.25	29	17	20,605	68
JM10M	JML10M	10	27	14	10.5	19.05	48	M10 X 1.5	29	17	20,605	68
JM12MF	JML12MF	12	30	16	12	22.23	54	M12 X 1.25	33	17	18,215	78
JM12M	JML12M	12	30	16	12	22.23	54	M12 X 1.75	33	17	18,215	78
JM14MF	JML14MF	14	34.75	19	13.50	25.40	60	M14 X 1.5	36	21	29,840	118
JM14M	JML14M	14	34.75	19	13.50	25.40	60	M14 X 2.0	36	21	29,840	118
JM16MF	JML16MF	16	38	21	14.25	28.58	66	M16 X 1.5	40	23	32,225	173
JM16M	JML16M	16	38	21	14.25	28.58	66	M16 X 2.0	40	23	32,225	173
JM18M	JML18M	18	42	23	16.25	31.75	72	M18 X 1.5	44	21	41,300	260
JM20M	JML20M	20	46	25	18	34.93	78	M20 X 1.5	47	20	50,952	290
JM20MC	JML20MC	20	46	25	18	34.93	78	M20 X 2.5	47	20	50,952	290
JM22M <sup>(1)</sup>	JML22M <sup>(1)</sup>	22	50	28	19.50	38.10	86	M22 X 1.5	51	22	56,238	315
JM25M <sup>(1)</sup>	JML25M <sup>(1)</sup>	25	60	31	22	42.86	95	M24 X 2.0	57	19	104,435	500
JM30M <sup>(1)(2)</sup>	JML30M <sup>(1)(2)</sup>	30	74.93	34.925	25.78	47.62	114.3	M30 X 2.0	63.5	17	193,732	1,224

<sup>(1)</sup> CHECK FOR AVAILABILITY

<sup>(2)</sup> TOLERANCE VARIATION FOR "D" & "A" ARE +/- .020

AVAILABLE OPTIONS	SUFFIX	EXAMPLE
PTFE LINER	T	JM10MT
GREASE FITTING	Z	JM10MZ
STUD (SEE PG 45 FOR STUD SPECS)	Y	JM10MY

BALL	BODY
52100 STEEL Rc 56 MIN HARD HARD CHROME PLATED	LOW CARBON STEEL ZINC PLATED CHROMATE TREATED
RACE	
STEEL ALLOY - HEAT TREATED ZINC PLATED CHROMATE TREATED	
LINER (OPTIONAL)	
PTFE FABRIC	

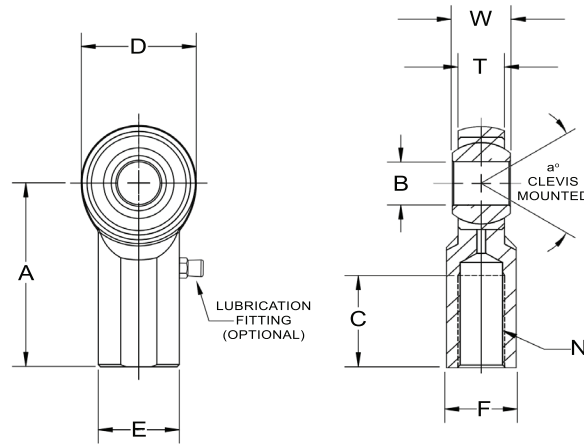

JF-M / JFL-M  
3-PIECE FEMALE METRIC, PRECISION  
METRIC

FEMALE ROD ENDS		B DIA	D DIA	W WIDTH	T WIDTH	BALL DIA	A LGTH	N THD	C LGTH	E DIA.	F FLAT	a° MIS ANGLE	ULT. STATIC RADIAL LOAD Newton	APPROX. WEIGHT (GRAMS)
RIGHT HAND PART NO.	LEFT HAND PART NO.	+0.065 -0.013	+0.38 -0.38	+0.13 -0.13	+0.13 -0.13	REF.	+0.40 -0.40	MM	+1.00 -1.00	+0.25 -0.25	+0.25 -0.25	REF.		
JF5M	JFL5M	5	16	8	6.25	11.10	27	M5 X 0.8	14	11	9	14	7,090	17
JF6M	JFL6M	6	19	9	7	12.70	30	M6 X 1.0	14	13	11	13	10,575	25
JF8MF	JFL8MF	8	22.25	12	8.75	15.88	36	M8 X 1.0	17	16	14	18	14,075	40
JF8M	JFL8M	8	22.25	12	8.75	15.88	36	M8 X 1.25	17	16	14	18	14,075	40
JF10MF	JFL10MF	10	27	14	10.5	19.05	43	M10 X 1.25	21	19	17	17	20,605	80
JF10M	JFL10M	10	27	14	10.5	19.05	43	M10 X 1.5	21	19	17	17	20,605	80
JF12MF	JFL12MF	12	30	16	12	22.23	50	M12 X 1.25	24	22	19	17	18,215	95
JF12M	JFL12M	12	30	16	12	22.23	50	M12 X 1.75	24	22	19	17	18,215	95
JF14MF	JFL14MF	14	34.75	19	13.50	25.40	57	M14 X 1.5	27	25	22	21	29,840	160
JF14M	JFL14M	14	34.75	19	13.50	25.40	57	M14 X 2.0	27	25	22	21	29,840	160
JF16MF	JFL16MF	16	38	21	14.25	28.58	64	M16 X 1.5	33	27	22	23	32,225	215
JF16M	JFL16M	16	38	21	14.25	28.58	64	M16 X 2.0	33	27	22	23	32,225	215
JF18M	JFL18M	18	42	23	16.25	31.75	71	M18 X 1.5	36	28.58	25.4	21	41,305	300
JF20M	JFL20M	20	46	25	18	34.93	77	M20 X 1.5	40	30.15	27	20	50,955	350
JF20MC	JFL20MC	20	46	25	18	34.93	77	M20 X 2.5	40	30.15	27	20	50,955	350
JF22M <sup>(1)</sup>	JFL22M <sup>(1)</sup>	22	50	28	19.50	38.10	86	M22 X 1.5	43	37	32	22	56,240	390
JF25M <sup>(1)</sup>	JFL25M <sup>(1)</sup>	25	60	31	22	42.86	95	M24 X 2.0	48	42	36	19	104,435	700
JF30M <sup>(1)(2)</sup>	JFL30M <sup>(1)(2)</sup>	30	69.85	34.925	25.4	47.625	104.78	M30 X 2.0	53.98	41.28	38.1	17	193,732	1093

<sup>(1)</sup> CHECK FOR AVAILABILITY

<sup>(2)</sup> TOLERANCE VARIATION FOR "D" & "A" ARE +/- .020

BALL	BODY
52100 STEEL Rc 56 MIN HARD HARD CHROME PLATED	LOW CARBON STEEL ZINC PLATED CHROMATE TREATED
RACE	
STEEL ALLOY - HEAT TREATED ZINC PLATED CHROMATE TREATED	
LINER (OPTIONAL)	
PTFE FABRIC	

AVAILABLE OPTIONS	SUFFIX	EXAMPLE
PTFE LINER	T	JF10MT
GREASE FITTING	Z	JF10MZ
STUD (SEE PG 45 FOR STUD SPECS)	Y	JF10MY

# JMX-M / JMXL-M

3-PIECE MALE METRIC, HIGH STRENGTH - PRECISION - WEAR RESISTANT / PTFE LINERS AVAILABLE

## METRIC

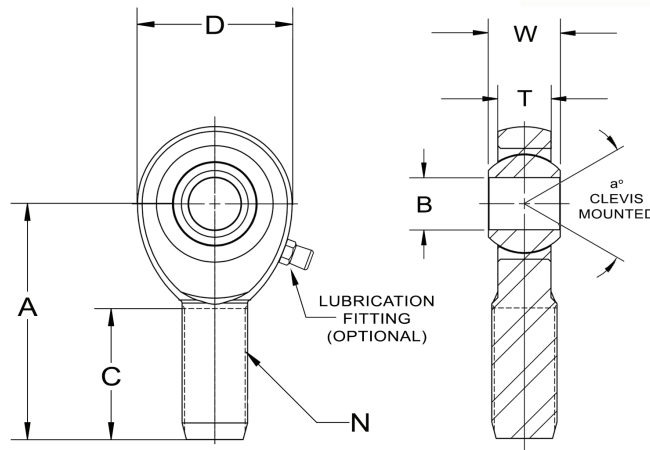

**JMX-M / JMXL-M**  
3-PIECE MALE METRIC, HIGH STRENGTH-PRECISION

MALE ROD ENDS		B DIA	D DIA	W WIDTH	T WIDTH	BALL DIA	A LGTH	N THD	C LGTH	a° MIS ANGLE	ULT. STATIC RADIAL LOAD Newton	APPROX. WEIGHT (GRAMS)
RIGHT HAND PART NO.	LEFT HAND PART NO.	+0.065 -0.013	+0.38 -0.38	+0.13 -0.13	+0.13 -0.13	REF.	+0.40 -0.40	MM	+1.00 -1.00	REF.		
JMX5M	JMXL5M	5	16	8	6.25	11.10	33	M5 X 0.8	20	14	12,614	13
JMX6M	JMXL6M	6	19	9	7	12.70	36	M6 X 1.0	22	13	17,725	18
JMX8MF	JMXL8MF	8	22.25	12	8.75	15.88	42	M8 X 1.0	25	18	33,137	31
JMX8M	JMXL8M	8	22.25	12	8.75	15.88	42	M8 X 1.25	25	18	33,137	31
JMX10MF	JMXL10MF	10	27	14	10.5	19.05	48	M10 X 1.25	29	17	50,225	68
JMX10M	JMXL10M	10	27	14	10.5	19.05	48	M10 X 1.5	29	17	50,225	68
JMX12MF	JMXL12MF	12	30	16	12	22.23	54	M12 X 1.25	33	17	44,487	78
JMX12M	JMXL12M	12	30	16	12	22.23	54	M12 X 1.75	33	17	44,487	78
JMX14MF	JMXL14MF	14	34.75	19	13.50	25.40	60	M14 X 1.5	36	21	71,745	118
JMX14M	JMXL14M	14	34.75	19	13.50	25.40	60	M14 X 2.0	36	21	71,745	118
JMX16MF	JMXL16MF	16	38	21	14.25	28.58	66	M16 X 1.5	40	23	76,290	173
JMX16M	JMXL16M	16	38	21	14.25	28.58	66	M16 X 2.0	40	23	76,290	173
JMX18M	JMXL18M	18	42	23	16.25	31.75	72	M18 X 1.5	44	21	100,740	260
JMX20M	JMXL20M	20	46	25	18	34.93	78	M20 X 1.5	47	20	120,210	290
JMX20MC	JMXL20MC	20	46	25	18	34.93	78	M20 X 2.5	47	20	120,210	290
JMX22M <sup>(1)</sup>	JMXL22M <sup>(1)</sup>	22	50	28	19.50	38.10	86	M22 X 1.5	51	22	137,100	315
JMX25M <sup>(1)</sup>	JMXL25M <sup>(1)</sup>	25	60	31	22	42.86	95	M24 X 2.0	57	19	251,780	500
JMX30M <sup>(1)(2)</sup>	JMXL30M <sup>(1)(2)</sup>	30	74.93	34.925	25.78	47.62	114.3	M30 X 2.0	63.5	17	476,745	1,224

<sup>(1)</sup> CHECK FOR AVAILABILITY

<sup>(2)</sup> TOLERANCE VARIATION FOR "D" & "A" ARE +/- .020

AVAILABLE OPTIONS	SUFFIX	EXAMPLE
PTFE LINER	T	JMX10MT
GREASE FITTING	Z	JMX10MZ
STUD (SEE PG 45 FOR STUD SPECS)	Y	JMX10MY

BALL	BODY
52100 STEEL Rc 56 MIN HARD HARD CHROME PLATED	STEEL ALLOY-HEAT TREATED ZINC PLATED CHROMATE TREATED
RACE	
STEEL ALLOY - HEAT TREATED ZINC PLATED CHROMATE TREATED	
LINER (OPTIONAL)	
PTFE FABRIC	

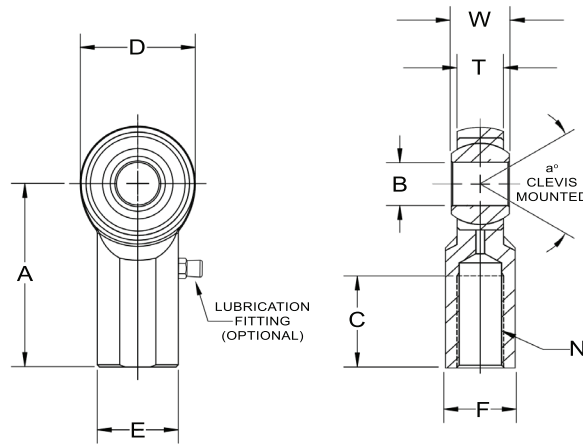

**JFX-M / JFXL-M**  
 3-PIECE FEMALE METRIC, HIGH STRENGTH-PRECISION  
**METRIC**

FEMALE ROD ENDS		B DIA	D DIA	W WIDTH	T WIDTH	BALL DIA	A LGTH	N THD	C LGTH	E DIA.	F FLAT	a° MIS ANGLE	ULT. STATIC RADIAL LOAD Newton	APPROX. WEIGHT (GRAMS)
RIGHT HAND PART NO.	LEFT HAND PART NO.	+0.065 -0.013	+0.38 -0.38	+0.13 -0.13	+0.13 -0.13	REF.	+0.40 -0.40	MM	+1.00 -1.00	+0.25 -0.25	+0.25 -0.25	REF.		
JFX5M	JFXL5M	5	16	8	6.25	11.10	27	M5 X 0.8	14	11	9	14	16,400	17
JFX6M	JFXL6M	6	19	9	7	12.70	30	M6 X 1.0	14	13	11	13	25,785	25
JFX8MF	JFXL8MF	8	22.25	12	8.75	15.88	36	M8 X 1.0	17	16	14	18	33,215	40
JFX8M	JFXL8M	8	22.25	12	8.75	15.88	36	M8 X 1.25	17	16	14	18	33,215	40
JFX10MF	JFXL10MF	10	27	14	10.5	19.05	43	M10 X 1.25	21	19	17	17	50,230	80
JFX10M	JFXL10M	10	27	14	10.5	19.05	43	M10 X 1.5	21	19	17	17	50,230	80
JFX12MF	JFXL12MF	12	30	16	12	22.23	50	M12 X 1.25	24	22	19	17	44,490	95
JFX12M	JFXL12M	12	30	16	12	22.23	50	M12 X 1.75	24	22	19	17	44,490	95
JFX14MF	JFXL14MF	14	34.75	19	13.50	25.40	57	M14 X 1.5	27	25	22	21	71,745	160
JFX14M	JFXL14M	14	34.75	19	13.50	25.40	57	M14 X 2.0	27	25	22	21	71,745	160
JFX16MF	JFXL16MF	16	38	21	14.25	28.58	64	M16 X 1.5	33	27	22	23	76,295	215
JFX16M	JFXL16M	16	38	21	14.25	28.58	64	M16 X 2.0	33	27	22	23	76,295	215
JFX18M	JFXL18M	18	42	23	16.25	31.75	71	M18 X 1.5	36	28.58	25.4	21	100,740	300
JFX20M	JFXL20M	20	46	25	18	34.93	77	M20 X 1.5	40	30.15	27	20	120,210	350
JFX20MC	JFXL20MC	20	46	25	18	34.93	77	M20 X 2.5	40	30.15	27	20	120,210	350
JFX22M <sup>(1)</sup>	JFXL22M <sup>(1)</sup>	22	50	28	19.50	38.10	86	M22 X 1.5	43	37	32	22	137,100	390
JFX25M <sup>(1)</sup>	JFXL25M <sup>(1)</sup>	25	60	31	22	42.86	95	M24 X 2.0	48	42	36	19	251,780	700
JFX30M <sup>(1)(2)</sup>	JFXL30M <sup>(1)(2)</sup>	30	69.85	34.925	25.4	47.625	104.78	M30 X 2.0	53.98	41.28	38.1	17	338,960	1093

<sup>(1)</sup> CHECK FOR AVAILABILITY

<sup>(2)</sup> TOLERANCE VARIATION FOR "D" & "A" ARE +/- .020

BALL	BODY
52100 STEEL Rc 56 MIN HARD HARD CHROME PLATED	STEEL ALLOY-HEAT TREATED ZINC PLATED CHROMATE TREATED
RACE	STEEL ALLOY - HEAT TREATED ZINC PLATED CHROMATE TREATED
LINER (OPTIONAL)	PTFE FABRIC

AVAILABLE OPTIONS	SUFFIX	EXAMPLE
PTFE LINER	T	JFX10MT
GREASE FITTING	Z	JFX10MZ
STUD (SEE PG 45 FOR STUD SPECS)	Y	JFX10MY

# COM / COMH

COMMERCIAL SERIES SPHERICAL BEARINGS / PTFE LINERS AVAILABLE

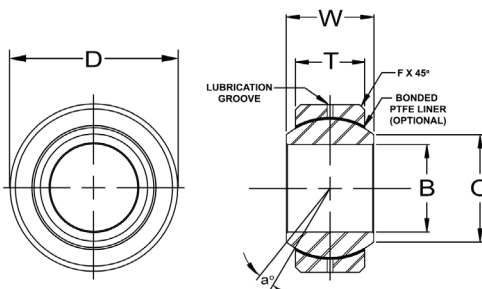

COM / COMH  
COMMERCIAL SERIES SPHERICAL BEARINGS

BEARING PART NO.	B DIA	D DIA	W WIDTH	T WIDTH	O DIA.	BALL DIA	F CHAMFER	a° MIS ANGLE	ULT. STATIC RADIAL LOAD (lbs.)	APPROX. WEIGHT (lbs.)
	+0.0015 -0.0005	+0.0000 -0.0007	+0.005 -0.005	+0.005 -0.005	REF.	REF.	REF.	REF.		
COM3	.1900	.5625	.281	.218	.293	.406	.015	11	3,250	.014
COM4	.2500	.6562	.343	.250	.364	.500	.022	13.5	4,950	.022
COM5	.3125	.7500	.375	.281	.419	.562	.032	12	6,475	.030
COM6	.3750	.8125	.406	.312	.516	.656	.032	10	8,400	.038
COM7	.4375	.9062	.437	.343	.530	.687	.032	8	9,453	.047
COM8	.5000	1.0000	.500	.390	.600	.781	.032	9.5	13,250	.065
COM8-101	.5000	1.0000	1.000	.390	.600	.781	.032	9.5	13,250	.065
COM8-103	.5000	1.0000	1.500	.390	.600	.781	.032	9.5	13,250	.065
COM9	.5625	1.0937	.562	.437	.671	.875	.032	9.5	16,630	.086
COM10	.6250	1.1875	.625	.500	.739	.968	.032	8.5	21,280	.110
COM12	.7500	1.4375	.750	.593	.920	1.187	.044	9	31,920	.204
COM12T-3R**	.7500	1.4375	.750	.593	.920	1.187	.044	9	31,920	.204
COM14	.8750	1.5625	.875	.703	.980	1.312	.044	9.5	41,960	.263
COM16	1.0000	1.7500	1.000	.797	1.118	1.500	.044	10	55,200	.386
COMH16***	1.0000	2.0000	1.000	.781	1.360	1.687	.032	9	70,820	.553
COMH19***	1.1875	2.3750	1.187	.937	1.610	2.000	.032	8.5	100,730	.895
COMH20***	1.2500	2.3750	1.187	.937	1.610	2.000	.032	8.5	100,730	.895
COMH24***	1.5000	2.7500	1.375	1.094	1.860	2.312	.032	8.5	135,950	1.358
COMH28***	1.7500	3.1250	1.562	1.250	2.110	2.625	.044	8	176,370	1.948
COMH32***	2.0000	3.5000	1.750	1.375	2.360	2.937	.044	8.5	217,060	2.650

\*\* BEARING COMES STANDARD WITH SNAP RING AND PTFE LINER. CONTACT FK ENGINEERING FOR FURTHER INFORMATION.  
\*\*\* BORE TOLERANCE: +.0025 / -.0005

**NOTES:**

LUBRICATION GROOVES IN I.D. & O.D OF RACE

FOR PTFE LINER, ADD "T" TO SUFFIX.

EXAMPLE: COM12T

(UNITS WITH PTFE LINERS HAVE NO LUBRICATION HOLES OR GROOVES IN RACE.)

<b>BALL</b>
52100 STEEL Rc 56 MIN HARD HARD CHROME PLATED
<b>RACE</b>
LOW CARBON STEEL OIL COATED
<b>LINER (OPTIONAL)</b>
PTFE FABRIC

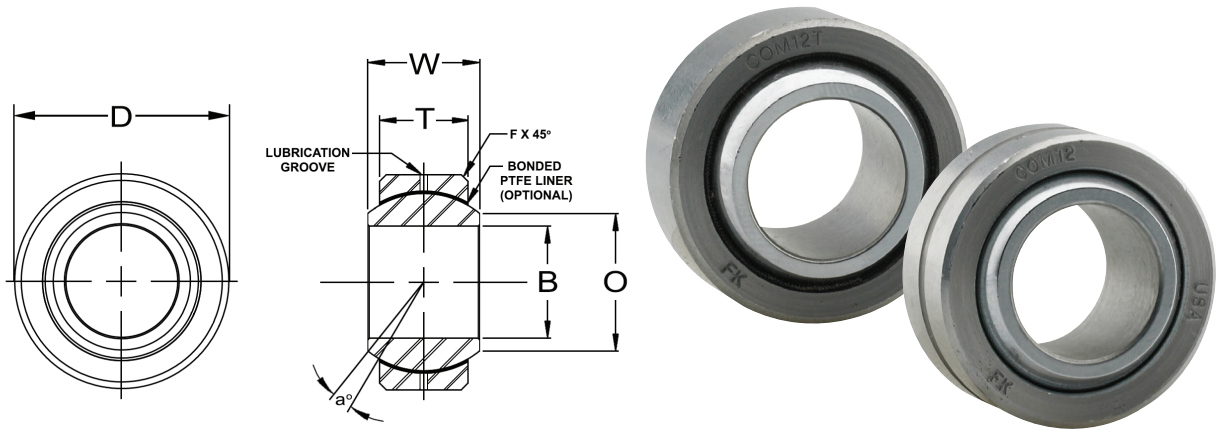

BEARING PART NO.	B DIA	D DIA	W WIDTH	T WIDTH	O DIA.	BALL DIA	F CHAMFER	a° MIS ANGLE	ULT. STATIC RADIAL LOAD (NEWTONS)	APPROX. WEIGHT (kg)
	+0.065 -0.013	+0.0000 -0.0127	+0.13 -0.13	+0.13 -0.13	REF.	REF.	REF.	REF.		
COM5M	5	13	8	6	7.7	11.10	.38	13	15,000	.006
COM6M	6	16	9	6.75	8.9	12.70	.56	13	19,300	.010
COM8M	8	19	12	9	10.3	15.88	.81	14	32,000	.018
COM10M	10	22	14	10.5	12.9	19.05	.81	13	45,000	.027
COM12M	12	26	16	12	15.4	22.23	.81	13	60,000	.043
COM14M	14	28	19	13.5	16.8	25.40	.81	16	76,500	.055
COM16M	16	32	21	15	19.3	28.58	.81	15	96,500	.08
COM18M	18	35	23	16.5	21.8	31.75	.81	15	118,000	.10
COM20M	20	40	25	18	24.3	34.93	.81	14	140,000	.15
COM22M	22	42	28	20	25.8	38.10	1.1	15	170,000	.18
COM25M	25	47	31	22	29.5	42.85	1.1	15	212,000	.24
COM30M	30	55	34.925	25	34.8	47.62	1.1	17	285,000	.38

<b>BALL</b>
52100 STEEL Rc 56 MIN HARD HARD CHROME PLATED
<b>RACE</b>
LOW CARBON STEEL OIL COATED
<b>LINER (OPTIONAL)</b>
PTFE FABRIC

**NOTES:**

LUBRICATION GROOVES IN I.D. & O.D OF RACE

FOR PTFE LINER, ADD "T" TO SUFFIX.  
EXAMPLE: COM12MT  
(UNITS WITH PTFE LINERS HAVE NO LUBRICATION HOLES OR GROOVES IN RACE.)

**COM-M**  
COMMERCIAL SERIES METRIC SPHERICAL BEARINGS  
**METRIC**

# FKS / FKS-T

HEAVY DUTY PRECISION SERIES SPHERICAL BEARINGS, ALLOY STEEL / PTFE LINERS AVAILABLE

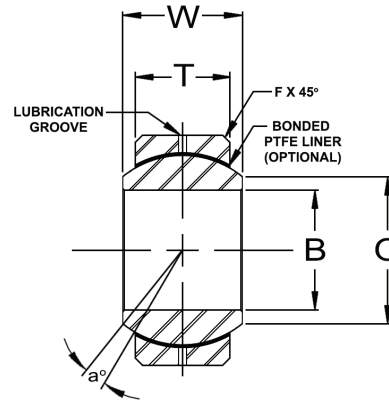
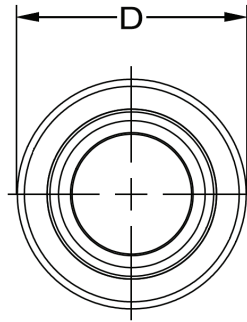

FKS / FKS-T  
HEAVY DUTY PRECISION SERIES SPHERICAL BEARINGS, ALLOY STEEL

BEARING PART NO.	B DIA	D DIA	W WIDTH	T WIDTH	O DIA.	BALL DIA	F CHAMFER	a° MIS ANGLE	ULT. STATIC RADIAL LOAD (lbs.)	APPROX. WEIGHT (lbs.)
	+0.0015 -0.0005	+0.0000 -0.0005	+0.005 -0.005	+0.005 -0.005	REF.	REF.	REF.	REF.		
FKS3	.1900	.5625	.281	.218	.293	.406	.015	11	6,480	.014
FKS4	.2500	.6562	.343	.250	.364	.500	.022	13.5	10,000	.022
FKS5	.3125	.7500	.375	.281	.419	.562	.032	12	13,900	.065
FKS6	.3750	.8125	.406	.312	.516	.656	.032	10	18,000	.038
FKS7	.4375	.9062	.437	.343	.530	.687	.032	8	22,300	.047
FKS8	.5000	1.0000	.500	.390	.600	.781	.032	9.5	26,900	.065
FKS9	.5625	1.0937	.562	.437	.671	.875	.032	9.5	36,000	.086
FKS10	.6250	1.1875	.625	.500	.739	.968	.032	8.5	48,000	.110
FKS12	.7500	1.4375	.750	.593	.920	1.187	.044	9	78,000	.204
FKS14	.8750	1.5625	.875	.703	.980	1.312	.044	9.5	103,000	.263
FKS16	1.0000	1.7500	1.000	.797	1.118	1.500	.044	10	125,000	.386
FKS24	1.5000	2.7500	1.375	1.094	1.860	2.312	.032	8.5	208,495	1.36

**NOTES:**

LUBRICATION GROOVES IN I.D. & O.D OF RACE

FOR PTFE LINER, ADD "T" TO SUFFIX.

EXAMPLE: FKS10T

(UNITS WITH PTFE LINERS HAVE NO LUBRICATION HOLES OR GROOVES IN RACE.)

<b>BALL</b>
52100 STEEL HEAT TREATED HARD CHROME PLATED
<b>RACE</b>
ALLOY STEEL HEAT TREATED OIL COATED
<b>LINER (OPTIONAL)</b>
PTFE FABRIC

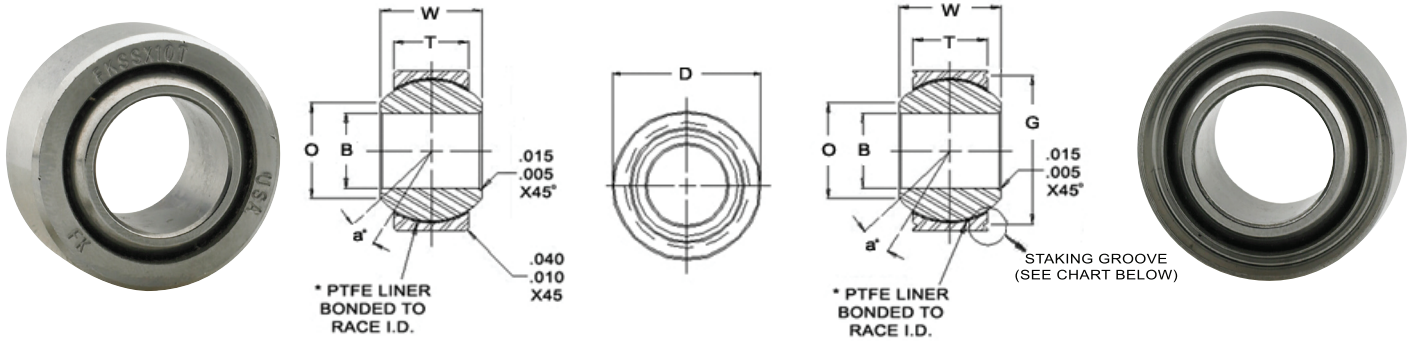

FKSSX-T / FKSSX-TV  
PRECISION SERIES SPHERICAL BEARINGS, PTFE LINED

BEARING PART NO.	B DIA	D DIA	W WIDTH	T WIDTH	O DIA.	G DIA.	BALL DIA.	a° MIS AN- GLE	LOAD RATINGS (lbs.)			APPROX. WEIGHT (lbs.)
									ULTIMATE	STATIC LIMIT	OSCILLATING LOAD (lbs.) PTFE LINED	
PLAIN	+0.0000 -0.0005	+0.0000 -0.0005	+0.000 -0.005	+0.005 -0.005	REF.	+0.000 -0.008	REF.	MIN.	RADIAL (lbs.)	RADIAL (lbs.)	AXIAL (lbs.)	
FKSSX3	.1900	.5625	.281	.218	.293	.500	.406	11	4,800	3,975	150	1,500
FKSSX4	.2500	.6562	.343	.250	.364	.594	.500	13.5	7,500	6,040	430	3,320
FKSSX5	.3125	.7500	.375	.281	.419	.650	.562	12	10,400	8,750	700	5,460
FKSSX6	.3750	.8125	.406	.312	.516	.712	.656	10	14,000	10,540	1,100	6,600
FKSSX7	.4375	.9062	.437	.343	.530	.806	.687	9.5	16,750	13,200	1,400	8,050
FKSSX8	.5000	1.0000	.500	.390	.600	.876	.781	9.5	20,000	17,900	2,100	10,400
FKSSX9	.5625	1.0937	.562	.437	.671	.970	.875	9.5	27,000	23,200	3,680	13,000
FKSSX10	.6250	1.1875	.625	.500	.739	1.063	.968	8.5	36,000	30,500	4,720	16,450
FKSSX12	.7500	1.4375	.750	.593	.920	1.313	1.187	9	54,000	46,400	6,750	23,600
FKSSX14	.8750	1.5625	.875	.703	.980	1.438	1.312	9.5	77,000	62,200	9,350	30,250
FKSSX16	1.0000	1.7500	1.000	.797	1.118	1.626	1.500	10	93,500	82,200	12,160	38,000

BALL	RACE	LINER (OPTIONAL)
400 SERIES STAINLESS STEEL HEAT TREATED	17-4 PH STAINLESS STEEL HEAT TREATED	PTFE FABRIC

**NOTES:**

OPTIONAL PTFE LINER AVAILABLE ON FKSSX SERIES.  
ADD "T" TO SUFFIX. EXAMPLE: FKSSX10T

OPTIONAL STAKING GROOVE AVAILABLE ON FKSSX-T SERIES.  
ADD "V" TO SUFFIX. EXAMPLE: FKSSX10TV

\*PTFE LINERS ARE STANDARD ON GROOVED FKSSX SERIES

(UNITS WITH PTFE LINERS HAVE NO LUBRICATION HOLES OR LUBRICATION GROOVES IN RACE.)

DIAMETER "B" AND "D" ARE CONCENTRIC WITHIN .005 T.I.R.

NO LOAD BREAKAWAY TORQUE	
BORE SIZES	TORQUE
3 & 4	.25 to 5.0
5 thru 12	1.0 to 5.0
14 & 16	2.0 to 8.0

STAKING GROOVE DATA			
BORE SIZES	S LAND	R RAD.	P DEPTH
		MIN.	+0.002 -0.005
3 & 4	.010	.010	.025
5	.020	.010	.035
6 & 7	.020	.015	.035
8 thru 16	.020	.015	.055

# WSSX-T / WSSX-TV

WIDE SERIES SPHERICAL BEARINGS, PTFE LINED

WSSX-T / WSSX-TV  
WIDE SERIES SPHERICAL BEARINGS, PTFE LINED

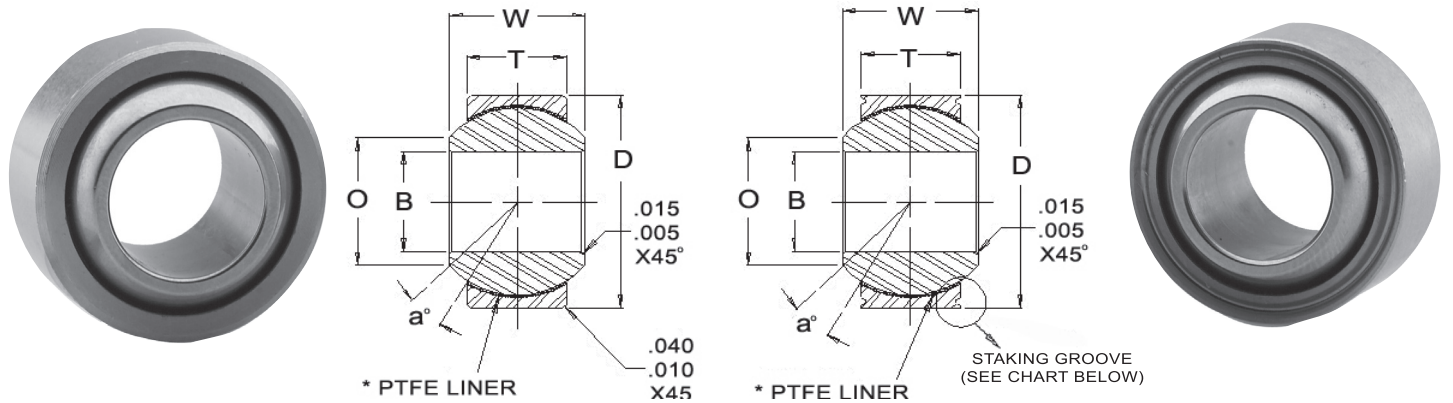

BEARING PART NO.		B DIA	D DIA	W WIDTH	T WIDTH	O SHOULDER DIA.	BALL DIA.	a° MIS ANGLE	LOAD RATINGS (lbs.)			APPROX. WEIGHT (lbs.)
PLAIN	GROOVED	+0.000 -0.005	+0.000 -0.005	+0.000 -0.002	+0.005 -0.005	REF.	REF.	MIN.	STATIC LIMIT	AXIAL	DYNAMIC OSCILLATING LOAD	
									(lbs.)	(lbs.)	(lbs.)	
WSSX3T	WSSX3TV	.1900	.6250	.437	.327	.301	.531	15	2,500	1,770	4,900	.031
WSSX4T	WSSX4TV	.2500	.6250	.437	.327	.301	.531	15	5,500	1,770	4,900	.031
WSSX5T	WSSX5TV	.3125	.6875	.437	.317	.360	.593	14	9,400	1,640	6,050	.035
WSSX6T	WSSX6TV	.3750	.8125	.500	.406	.466	.687	8	13,700	2,630	8,310	.060
WSSX7T	WSSX7TV	.4375	.9375	.562	.442	.537	.781	10	20,700	3,650	11,750	.080
WSSX8T	WSSX8TV	.5000	1.0000	.625	.505	.607	.875	9	21,400	4,970	14,950	.100
WSSX9T	WSSX9TV	.5625	1.1250	.687	.536	.721	1.000	10	26,600	5,370	18,100	.135
WSSX10T	WSSX10TV	.6250	1.1875	.750	.567	.747	1.062	12	29,000	6,130	20,250	.160
WSSX12T	WSSX12TV	.7500	1.3750	.875	.630	.845	1.250	13	37,000	7,730	26,200	.240
WSSX14T	WSSX14TV	.8750	1.6250	.875	.755	1.061	1.375	6	65,200	10,800	33,600	.350
WSSX16T	WSSX16TV	1.0000	2.1250	1.375	1.005	1.269	1.875	12	104,000	19,300	56,250	.970
WSSX24T**	WSSX24TV**	1.5000	2.9170	1.962	1.500	1.927	2.750	11	281,531	43,180	112,527	2.250

**NOTES:**

DIAMETER "B" AND "D" ARE CONCENTRIC WITHIN .005 T.I.R.

\*\*WSSX24T - "B" TOLERANCE IS +.0015 / -.0005 & "W" TOLERANCE IS +.000 / -.005

BALL	RACE	LINER (STANDARD)
440 SERIES STAINLESS STEEL HEAT TREATED	17-4 PH STAINLESS STEEL HEAT TREATED	PTFE FABRIC

NO LOAD BREAKAWAY TORQUE	
BORE SIZES	TORQUE
3	.5 to 5.0 in. lbs.
4 thru 12	1.0 to 5.0 in. lbs.
14 thru 24	2.0 to 8.0 in. lbs.

STAKING GROOVE DATA				
BORE SIZES	S LAND	X GROOVE	R RAD.	P DEPTH
	+0.000 -0.010	+0.000 -0.010	+0.000 -0.010	+0.000 -0.015
3 thru 5	.020	.045	.015	.030
6 thru 10	.030	.055	.020	.040
12 thru 24	.030	.080	.020	.060

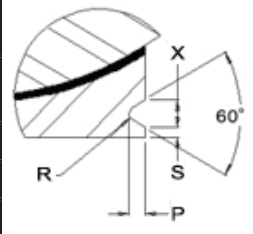

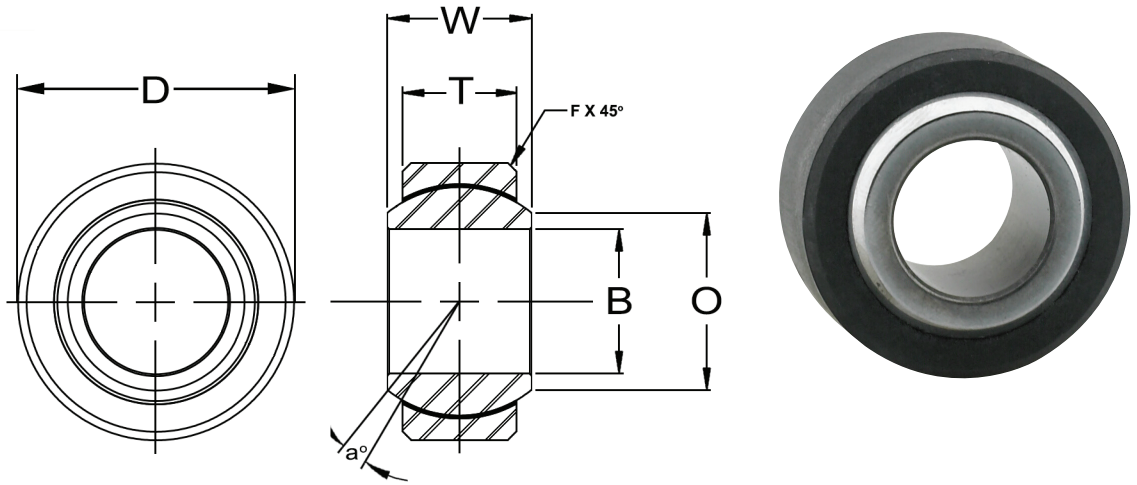

BEARING PART NO.	B DIA	D DIA	W WIDTH	T WIDTH	O DIA.	BALL DIA	F CHAMFER	a° MIS ANGLE	ULT. STATIC RADIAL LOAD (lbs.)	APPROX. WEIGHT (lbs.)
	+0.0025 -0.0005	+0.0000 -0.0010	+0.005 -0.005	+0.005 -0.005	REF.	REF.	REF.	REF.		
IN3P	.1900	.5000	.312	.250	.307	.437	.020	13	939	.010
IN4P	.2500	.5781	.375	.281	.331	.500	.025	16	1,734	.014
IN5P	.3125	.7031	.437	.344	.447	.625	.025	14	2,236	.024
IN6P	.3750	.8125	.500	.406	.516	.718	.030	12	3,209	.036
IN7P	.4375	.9375	.562	.437	.587	.812	.030	14	3,395	.050
IN8P	.5000	1.0625	.625	.500	.699	.937	.030	12	5,360	.074
IN10P	.6250	1.2500	.750	.562	.839	1.125	.030	16	5,920	.122
IN12P	.7500	1.4375	.875	.687	.978	1.312	.035	14	9,240	.188

BALL	RACE
LOW CARBON STEEL CASE HARDENED ZINC PLATED	PTFE LUBRICATED FIBER REINFORCED ENGINEERING PLASTIC

IN-P  
PRECISION PLASTIC RACE SERIES SPHERICAL BEARINGS, LIGHT DUTY

# GEZ-ES

## INCH - SPHERICAL PLAIN BEARINGS WITH SINGLE FRACTURED RACE

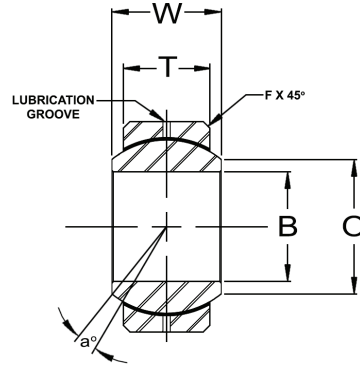
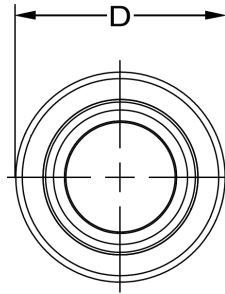

GEZ-ES INCH - SPHERICAL PLAIN BEARINGS WITH SINGLE FRACTURED RACE

BEARING PART NO.		B DIA.		D DIA.		W WIDTH		T WIDTH		O DIA.	F CMFR	a° MIS ANGLE	ULT. STATIC RADIAL LOAD (lbs.)	APPROX. WEIGHT (lbs.)
OPEN	SEALED	MAX.	MIN.	MAX.	MIN.	MAX.	MIN.	MAX.	MIN.	REF.	REF.	REF.		
GEZ8ES	N/A	.5000	.4995	.8750	.8745	.437	.432	.375	.365	.555	.024	6	9,217	.049
GEZ10ES	N/A	.6250	.6245	1.0625	1.0620	.547	.542	.469	.459	.720	.024	6	14,635	.079
GEZ12ES	GEZ12ES-2RS	.7500	.7495	1.2500	1.2495	.656	.651	.562	.552	.858	.024	6	21,356	.117
GEZ14ES	GEZ14ES-2RS	.8750	.8745	1.4375	1.4370	.765	.760	.656	.646	1.000	.024	6	28,550	.187
GEZ16ES	GEZ16ES-2RS	1.0000	.9995	1.6250	1.6245	.875	.870	.750	.740	1.087	.024	6	37,317	.267
GEZ20ES	GEZ20ES-2RS	1.2500	1.2495	2.0000	1.9995	1.093	1.088	.937	.925	1.417	.024	6	58,448	.512
GEZ22ES	GEZ22ES-2RS	1.3750	1.3745	2.1875	2.1870	1.187	1.182	1.031	1.019	1.515	.039	6	69,688	.773
GEZ24ES	GEZ24ES-2RS	1.5000	1.4995	2.4375	2.4370	1.312	1.307	1.125	1.113	1.622	.039	6	84,300	.930
GEZ28ES	GEZ28ES-2RS	1.7500	1.7495	2.8125	2.8120	1.531	1.526	1.312	1.300	1.996	.039	6	114,648	1.413
GEZ32ES	GEZ32ES-2RS	2.0000	1.9995	3.1875	3.1869	1.750	1.745	1.500	1.484	2.280	.039	6	150,616	2.055
GEZ36ES	GEZ36ES-2RS	2.2500	2.2494	3.5625	3.5619	1.969	1.963	1.687	1.671	2.555	.039	6	191,080	2.932
GEZ40ES	GEZ40ES-2RS	2.5000	2.4994	3.9375	3.9369	2.187	2.181	1.875	1.859	2.886	.039	6	238,288	4.079
GEZ44ES	GEZ44ES-2RS	2.7500	2.7494	4.3750	4.3744	2.406	2.400	2.062	2.046	3.114	.039	6	281,000	5.335
GEZ48ES	GEZ48ES-2RS	3.0000	2.9994	4.7500	4.7493	2.625	2.619	2.250	2.230	3.417	.039	6	337,200	6.834
GEZ52ES	GEZ52ES-2RS	3.2500	3.2492	5.1250	5.1243	2.844	2.836	2.437	2.417	3.720	.039	6	395,648	8.422
GEZ56ES	GEZ56ES-2RS	3.5000	3.4992	5.5000	5.4993	3.062	3.054	2.625	2.605	4.000	.039	6	458,595	10.560
GEZ60ES	GEZ60ES-2RS	3.7500	3.7492	5.8750	5.8743	3.281	3.273	2.812	2.792	4.280	.039	6	530,528	12.743
GEZ64ES	GEZ64ES-2RS	4.0000	3.9992	6.2500	6.2490	3.500	3.492	3.000	2.980	4.559	.039	6	595,720	15.410
GEZ68ES	GEZ68ES-2RS	4.2500	4.2492	6.6250	6.6240	3.719	3.711	3.187	3.167	4.835	.039	6	674,400	18.541
GEZ72ES	GEZ72ES-2RS	4.5000	4.4992	7.0000	6.9990	3.937	3.929	3.375	3.355	5.142	.039	6	764,320	21.583
GEZ76ES	GEZ76ES-2RS	4.7500	4.7490	7.3750	7.3738	4.156	4.148	3.562	3.542	5.417	.039	6	843,000	25.353
GEZ80ES	GEZ80ES-2RS	5.0000	4.9990	7.7500	7.7488	4.375	4.365	3.750	3.730	5.720	.039	6	932,920	29.762
GEZ96ES	GEZ96ES-2RS	6.0000	5.9990	8.7500	8.7488	4.750	4.740	4.125	4.105	6.622	.039	5	1,168,960	38.581

**NOTES:**

1. LUBRICATING HOLES AND GROOVES ARE LOCATED ON INNER AND OUTER RACES.

2. TYPE 2RS HAS SEALS ON BOTH SIDES.

BALL	RACE
ALLOY STEEL HEAT TREATED PHOSPHATE COATED	ALLOY STEEL, HEAT TREATED SINGLE FRACTURE PHOSPHATE COATED

CHECK AVAILABILITY ON ALL SIZES BEFORE ORDERING

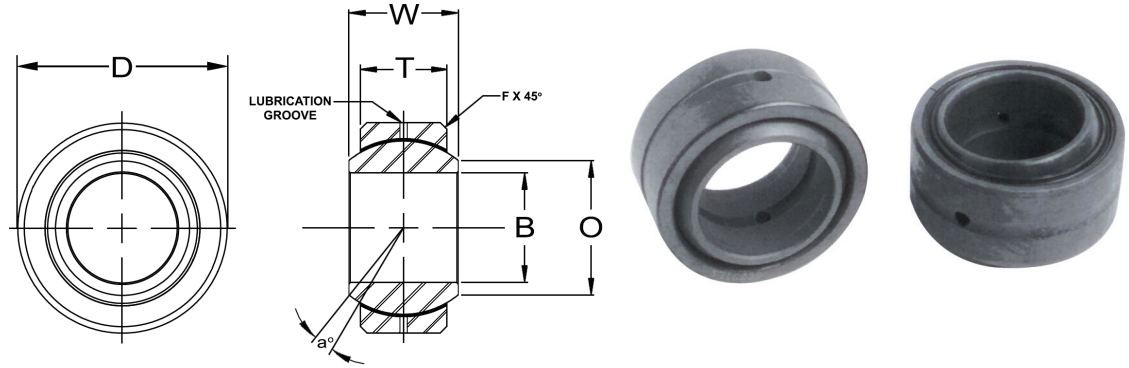

BEARING PART NO.		B DIA.		D DIA.		W WIDTH		T WIDTH		O DIA.	F CMFR	a° MIS ANGLE	ULT. STATIC RADIAL LOAD (kN)	APPROX. WEIGHT (kg)
OPEN	SEALED	MAX.	MIN.	MAX.	MIN.	MAX.	MIN.	MAX.	MIN.	REF.	REF.	REF.		
GE12E	N/A	12.000	11.992	22.000	21.991	10.00	9.88	7.00	6.76	15	0.3	11	54	.016
GE15ES	GE15ES-2RS	15.000	14.992	26.000	25.991	12.00	11.88	9.00	8.76	18	0.3	8	85	.025
GE17ES	GE17ES-2RS	17.000	16.992	30.000	29.991	14.00	13.88	10.00	9.76	20	0.3	10	106	.041
GE20ES	GE20ES-2RS	20.000	19.990	35.000	34.989	16.00	15.88	12.00	11.76	24	0.3	9	146	.061
GE25ES	GE25ES-2RS	25.000	24.990	42.000	41.989	20.00	19.88	16.00	15.76	29	0.6	7	240	.11
GE30ES	GE30ES-2RS	30.000	29.990	47.000	46.989	22.00	21.88	18.00	17.76	34	0.6	6	310	.14
GE35ES	GE35ES-2RS	35.000	34.988	55.000	54.987	25.00	24.88	20.00	19.70	39	1.0	6	400	.22
GE40ES	GE40ES-2RS	40.000	39.988	62.000	61.987	28.00	27.88	22.00	21.70	45	1.0	7	500	.30
GE45ES	GE45ES-2RS	45.000	44.988	68.000	67.987	32.00	31.88	25.00	24.70	50	1.0	7	640	.40
GE50ES	GE50ES-2RS	50.000	49.988	75.000	74.987	35.00	34.88	28.00	27.70	55	1.0	6	780	.54
GE60ES	GE60ES-2RS	60.000	59.985	90.000	89.985	44.00	43.85	36.00	35.60	66	1.0	6	1,220	1.00
GE70ES	GE70ES-2RS	70.000	69.985	105.000	104.985	49.00	48.85	40.00	39.60	77	1.0	6	1,560	1.50
GE80ES	GE80ES-2RS	80.000	79.985	120.000	119.985	55.00	54.85	45.00	44.60	88	1.0	6	2,000	2.20
GE90ES	GE90ES-2RS	90.000	89.980	130.000	129.982	60.00	59.80	50.00	49.50	98	1.0	5	2,450	2.70
GE100ES	GE100ES-2RS	100.000	99.980	150.000	149.982	70.00	69.80	55.00	54.50	109	1.0	7	3,050	4.30
GE110ES	GE110ES-2RS	110.000	109.980	160.000	159.975	70.00	69.80	55.00	54.50	120	1.0	6	3,250	4.70
GE120ES	GE120ES-2RS	120.000	119.980	180.000	179.975	85.00	84.80	70.00	69.50	130	1.0	6	4,750	8.00
GE140ES	GE140ES-2RS	140.000	139.975	210.000	209.970	90.00	89.75	70.00	69.40	150	1.0	7	5,400	11.00
GE160ES	GE160ES-2RS	160.000	159.975	230.000	229.970	105.00	104.75	80.00	79.40	170	1.0	8	6,800	14.00

**NOTES:**

1. LUBRICATING HOLES AND GROOVES ARE LOCATED ON INNER AND OUTER RACES.
2. TYPE 2RS HAS SEALS ON BOTH SIDES.

CHECK AVAILABILITY ON ALL SIZES BEFORE ORDERING

BALL	RACE
ALLOY STEEL HEAT TREATED PHOSPHATE COATED	ALLOY STEEL, HEAT TREATED SINGLE FRACTURE PHOSPHATE COATED

**GE-ES**  
METRIC - SPHERICAL PLAIN BEARINGS WITH SINGLE FRACTURED RACE  
**METRIC**

# AIN

HEAVY DUTY PRECISION SPHERICAL BEARINGS, ALLOY STEEL / PTFE LINERS AVAILABLE

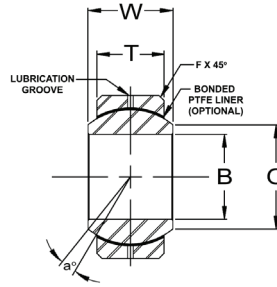
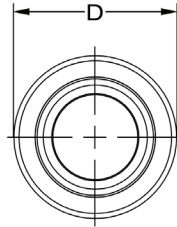

<b>RACE</b>
ALLOY STEEL HEAT TREATED OIL COATED
<b>BALL</b>
52100 STEEL Rc 56 MIN. HARD HARD CHROME PLATED

BEARING PART NO.	B DIA	D DIA	W WIDTH	T WIDTH	O DIA.	BALL DIA	F CHAMFER	α° MIS ANGLE	ULT. STATIC RADIAL LOAD (lbs.)	APPROX. WEIGHT (lbs.)
	+0.0015 -0.0005	+0.0000 -0.0007	+0.005 -0.005	+0.005 -0.005	REF.	REF.	REF.	REF.		
AIN3	.1900	.5312	.312	.250	.307	.437	.020	10.5	6,550	.016
AIN4	.2500	.6094	.375	.281	.331	.500	.020	14.5	8,427	.023
AIN5	.3125	.7500	.437	.344	.448	.625	.020	11.0	12,912	.039
AIN6	.3750	.8437	.500	.406	.516	.719	.020	9.5	17,512	.059
AIN7	.4375	1.0000	.562	.437	.587	.812	.020	11.0	21,290	.079
AIN8	.5000	1.0937	.625	.500	.699	.937	.020	9.5	28,110	.110
AIN10	.6250	1.3125	.750	.562	.839	1.125	.030	12.0	37,930	.165
AIN12	.7500	1.5000	.875	.687	.978	1.312	.030	10.0	48,675	.252
AIN14	.8750	1.5000	.875	.687	.978	1.312	.030	6.0	48,675	.248
AIN14T-770	.8750	1.6250	.875	.750	1.061	1.375	.035	6.0	58,650	.350
AIN16	1.0000	2.1250	1.375	1.000	1.275	1.875	.060	15.0	90,000	.788

AVAILABLE OPTIONS	SUFFIX	EXAMPLE
PTFE LINER	T	AIN10T

AIN / CP HEAVY DUTY PRECISION SPHERICAL BEARINGS, ALLOY STEEL

# CP

BEARING CUPS FOR SPHERICAL BEARINGS

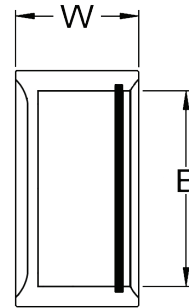
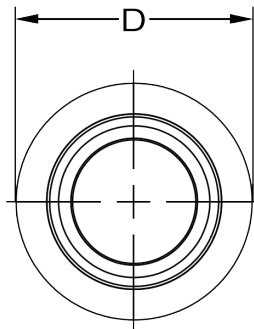

PART NO.	B	W	D	BEARING CUPS WILL FIT THE FOLLOWING PART NUMBERS	SNAP RING PART NO.
CP8	1.0000	.750	1.250	COM8, FKS8, FKSSX8T	SR8
CP10	1.1875	.875	1.500	COM10, FKS10, FKSSX10T	SR10
CP12	1.4375	1.000	1.750	COM12, FKS12, FKSSX12T	SR12
CPW12	1.3750	1.000	1.750	WSSX12T	SRW12
CPW14	1.6250	1.250	2.000	AIN14T-770, WSSX14T	SRW14
CPW16	2.1250	1.500	2.625	AIN16, WSSX16T	SRW16
CPW16-1	2.1250	2.500	2.625	AIN16, WSSX16T	SRW16
CP20	2.375	1.500	2.875	COMH20	SR20
CP24	2.750	1.625	3.500	COMH24	SR24

PRECISION MANUFACTURED FROM 4130 ALLOY STEEL AND ARE COMPLETE WITH SNAP RING RETAINER. FABRICATION OF PARTS USING THESE CUPS SHOULD BE PERFORMED BY A QUALIFIED WELDER. CUPS COME STANDARD WITH A SNAP RING. REPLACEMENT SNAP RINGS ARE AVAILABLE.

# SPECIAL SIZED ROD ENDS

2-PIECE, METAL TO METAL, SPECIAL BORE SIZES / PTFE LINERS AVAILABLE

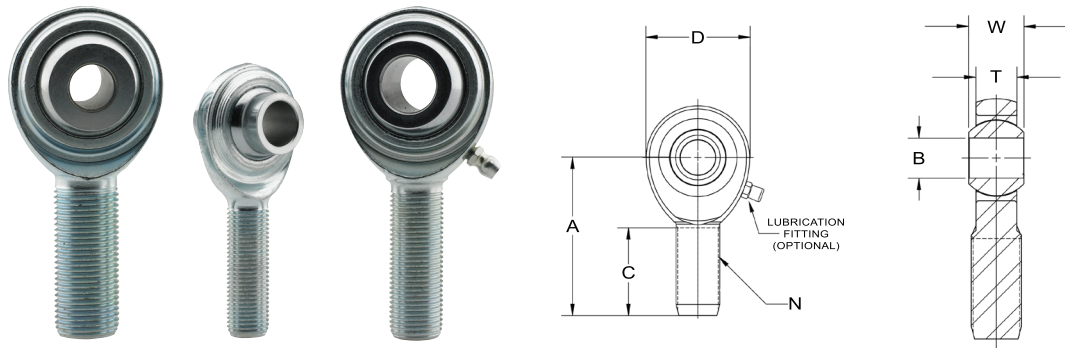

MALE ROD ENDS		B DIA	D DIA	T WIDTH	BALL DIA	A LGTH	N THD	C LGTH	ULT. STATIC RADIAL LOAD (lbs.)	APPROX. WEIGHT (lbs.)
RIGHT HAND PART NO.	LEFT HAND PART NO.									
CM4-3	CML4-3	.1900	.750	.250	.500	1.562	1/4-28	1.000	2,225	.042
CM5-4	CML5-4	.2500	.875	.312	.625	1.875	5/16-24	1.250	3,600	.074
CM6-5	CML6-5	.3125	1.000	.359	.719	1.938	3/8-24	1.250	5,100	.108
HCM6	HCML6	.3750	1.000	.359	.719	1.938	3/8-24	1.250	5,100	.110
CM8-6	CML8-6	.3750	1.312	.453	.937	2.438	1/2-20	1.500	8,386	.246
HCM8	HCML8	.5000	1.312	.453	.937	2.438	1/2-20	1.500	8,386	.256
CM10-8	CML10-8	.5000	1.500	.484	1.125	2.625	5/8-18	1.625	9,813	.380
CM12-8	CML12-8	.5000	1.750	.593	1.312	2.875	3/4-16	1.750	14,290	.626
CM12-10	CML12-10	.6250	1.750	.593	1.312	2.875	3/4-16	1.750	14,290	.596
CM10-12	CML10-12	.6250	1.750	.593	1.312	2.875	5/8-18	1.750	11,184	.532
HCM12	HCML12	.7500	1.750	.593	1.312	2.875	3/4-16	1.750	14,290	.582
CM12-757	CML12-757	.7570	1.750	.593	1.312	2.875	3/4-16	1.750	14,290	.560

\* CONSULT F.K. ENGINEERING DEPARTMENT

SPECIAL SIZED ROD ENDS / BALL JOINTS

## B

BALL JOINTS, SWAGED CONSTRUCTION WITH DIRT SHIELD

BODY	BALL STUD
LOW CARBON STEEL ZINC PLATED DICHROMATE TREATED	LOW CARBON STEEL HEAT TREATED ZINC PLATED DICHROMATE TREATED

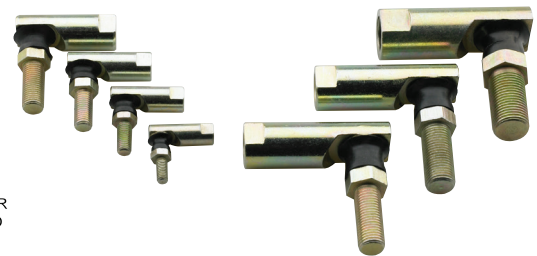
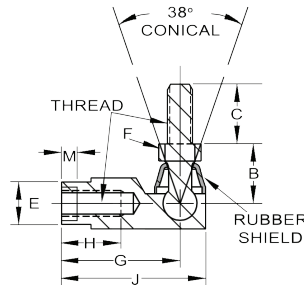

PART NUMBER	THREAD	B	C	E	F HEX	G	H	J	M	N FLAT	TENSILE & SHEAR STRENGTH (lbs.)	FORCE TO REMOVE STUD (lbs.)
B3	10-32	.438	.438	.375	.313	.875	.438	1.063	.218	.312	300	500
B4	1/4-28	.469	.563	.438	.375	.969	.500	1.219	.281	.375	850	837
B5	5/16-24	.531	.688	.500	.438	1.125	.563	1.406	.281	.438	1,500	1,000
B6	3/8-24	.688	.875	.625	.500	1.375	.750	1.688	.313	.500	2,400	1,512
B7	7/16-20	.875	1.125	.750	.625	1.938	1.000	2.375	.375	.625	2,700	2,173
B8	1/2-20	.875	1.125	.750	.625	1.938	1.000	2.375	.375	.625	2,700	2,400
B10	5/8-18	1.000	1.125	.875	.750	2.063	1.000	2.578	.500	.750	2,950	3,150

NOTES:

1. BALL CAVITY IS PRE-LOADED WITH HIGH IMPACT LUBRICANT

2. BALL JOINTS ARE SUPPLIED WITH A DIRT SHIELD FOR PROTECTION AGAINST CONTAMINANTS

# SOLID ROD ENDS

1-PIECE, METAL TO METAL

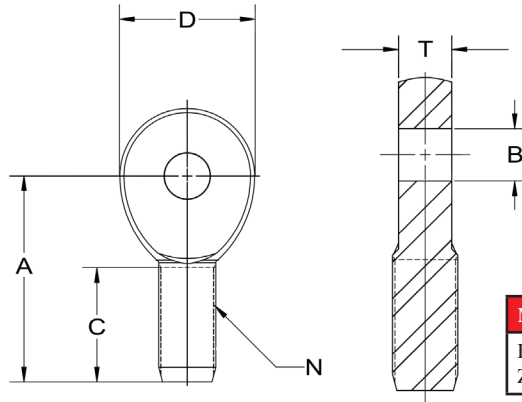

### MATERIALS

LOW CARBON STEEL  
ZINC PLATED

MALE PART NO.	BORE & THREAD	B DIA.	D DIA.	T WIDTH	A LENGTH	C LENGTH	N THREAD	ULT. STATIC RADIAL LOAD (lbs.)
	REF.	+0.0025 -.0005	+0.010 -.010	+0.005 -.005	+0.015 -.015	+0.062 -.031	UNF 3a	
RD1	5/8 X 5/8	.6250	1.500	.750	2.625	1.625	5/8-18	16,600
RD2	5/8 X 3/4	.6250	1.750	.875	2.875	1.750	3/4-16	18,500
RD3	3/4 X 3/4	.7500	1.750	.875	2.875	1.750	3/4-16	18,500
RD4	1/2 X 1/2	.5000	1.312	.625	2.437	1.500	1/2-20	12,100
RD5	1/2 X 3/4	.5000	1.750	.875	2.875	1.750	3/4-16	18,500
RD8	1/2 X 3/4	.5000	1.500	.750	2.625	1.625	3/4-16	18,500

# CLEVIS

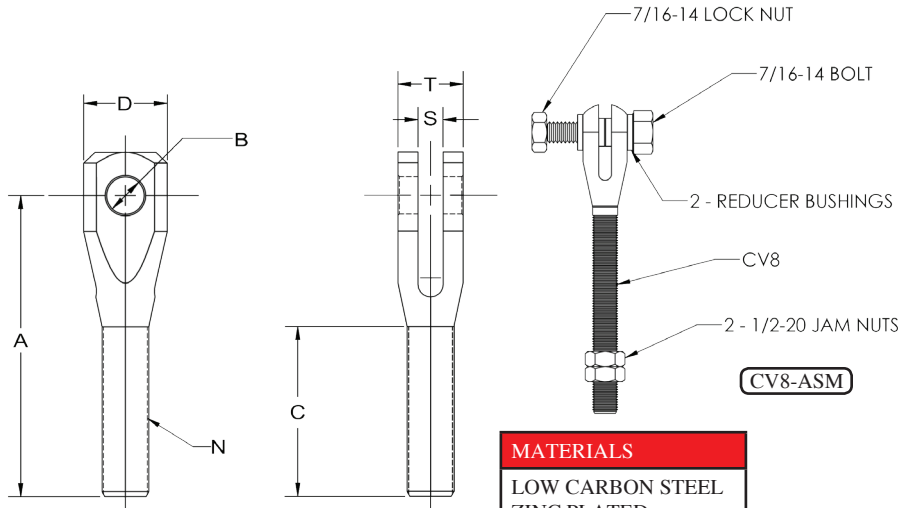

### MATERIALS

LOW CARBON STEEL  
ZINC PLATED  
CHROMATE TREATED

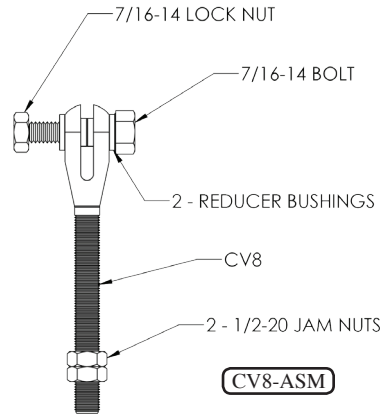

PART NO.	BORE & THREAD	B DIA.	D DIA.	T WIDTH	A LENGTH	C LENGTH	S SLOT	N THREAD
	REF.	+0.0025 -.0005	+0.010 -.010	+0.005 -.005	+0.015 -.015	+0.062 -.031	+0.005 -.005	UNF 3a
CV1	3/8 X 5/8	.3750	1.125	.825	3.375	2.000	.375	5/8-18
CV2	1/2 X 5/8	.5000	1.125	.825	3.375	2.000	.375	5/8-18
CV3	3/8 X 3/4	.3750	1.125	.825	3.375	2.000	.375	3/4-16
CV4	1/2 X 3/4	.5000	1.125	.825	3.375	2.000	.375	3/4-16
CV5	3/8 X 1/2	.3750	.875	.655	3.012	1.700	.250	1/2-20
CV8	9/16 X 1/2	.5625	1.125	.875	5.563	3.900	.250	1/2-20

**MATERIAL**  
17-4PH STAINLESS STEEL

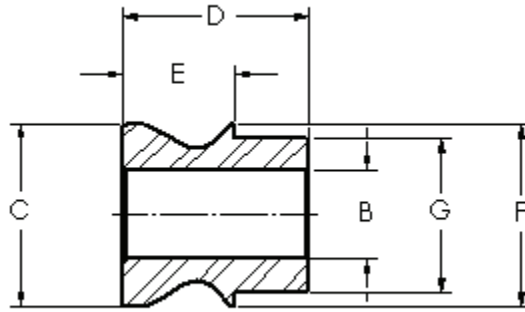

**HB**  
**HIGH MISALIGNMENT BUSHINGS**

PART NUMBER	B	C	D	E	F	G	MISALIGN ANGLE	ROD END & AIN SERIES BEARING SIZE
8-6HB	.3750	.645	.627	.342	.667	.499	50°	8
10-8HB	.5000	.840	.900	.530	.795	.624	58°	10
10-8HB-2	.5000	.840	1.620	1.250	.795	.624	58°	10
12-8HB	.5000	.995	.900	.475	.930	.749	60°	12
12-10HB	.6250	.995	.900	.475	.930	.749	48°	12
14-8HB	.5000	1.040	1.055	.625	1.035	.874	46°	RSMX14T JMX14T-770 KMX14
14-10HB	.6250	1.050	1.055	.625	1.035	.874	44°	
14-12HB	.7500	1.050	1.242	.812	1.035	.874	46°	
16-10HB	.6250	1.245	1.497	.817	1.225	.999	66°	16
16-10HB-2	.6250	1.135	1.370	.690	1.225	.999	66°	16
16-12HB	.7500	1.135	1.370	.690	1.225	.999	60°	16

- NOTES:  
 1. ALL DIMENSIONS ARE IN INCHES.  
 2. MISALIGNMENT BUSHINGS INCREASE MISALIGNMENT ANGLE AND REDUCE HOLE SIZES IN ROD ENDS AND SPHERICAL BEARINGS.  
 3. ALL BUSHINGS ARE SOLD IN PAIRS.  
 4. MISALIGNMENT BUSHINGS DO NOT FIT SJM & PMX SERIES ROD ENDS.

**LINKAGE ADJUSTER**



**MATERIALS**  
LOW CARBON STEEL  
ZINC PLATED  
CHROMATE TREATED

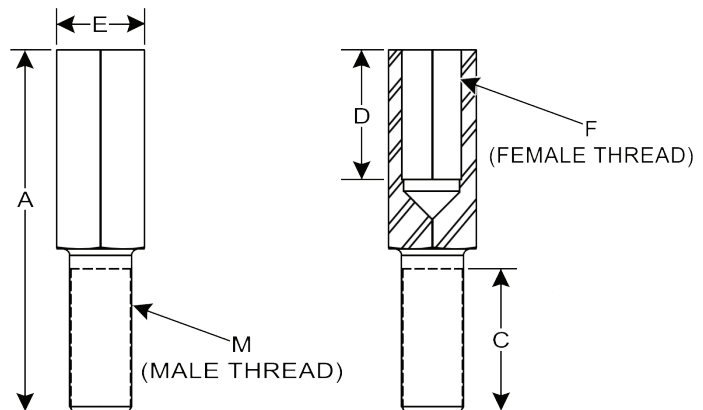

PART NO.	M THREAD	F THREAD	A LENGTH	C LENGTH	D LENGTH	E HEX
	UNF 3A	UNF 2B	+ .015 - .015	+ .062 - .031	+ .062 - .031	+ .005 - .005
ADJUSTERLADDER	3/4-16 LH	3/4-16 RH	4.125	1.625	1.562	1.000
ADJUSTERLADDER2	3/4-16 RH	3/4-16 LH	4.125	1.625	1.562	1.000

# JAM NUTS

STEEL & ALUMINUM JAM NUTS IN INCH & METRIC SIZES

JAM NUTS  
STEEL & ALUMINUM JAM NUTS IN INCH & METRIC SIZES

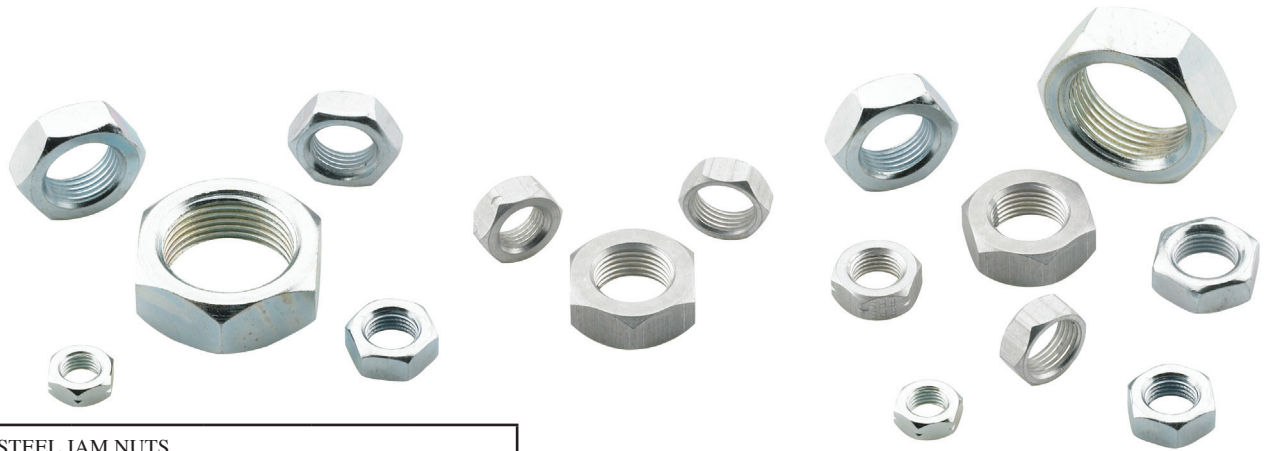

INCH STEEL JAM NUTS				
RIGHT HAND	LEFT HAND	THD. SIZE	HEX SIZE	W WIDTH
		UNF-2B	REF.	REF.
SJNR03	SJNL03	10-32	3/8	.160
SJNR04	SJNL04	1/4-28	7/16	.160
SJNR05	SJNL05	5/16-24	1/2	.187
SJNR06	SJNL06	3/8-24	9/16	.225
SJNR07	SJNL07	7/16-20	11/16	.250
SJNR08	SJNL08	1/2-20	3/4	.312
SJNR10	SJNL10	5/8-18	15/16	.375
SJNR10-1	SJNL10-1	5/8-18	3/4	.312
SJNR12	SJNL12	3/4-16	1 3/32	.425
SJNR12-1	SJNL12-1	3/4-16	15/16	.375
SJNR14*	SJNL14*	7/8-14	1 1/4	.500
SJNR16*	SJNL16*	1 1/4-12	1 5/8	.550
SJNR16-1*	SJNL16-1*	1-14	1 3/8	.550
SJNR16-2*	SJNL16-2*	1-12	1 3/8	.550

INCH ALUMINUM JAM NUTS				
RIGHT HAND	LEFT HAND	THD. SIZE	HEX SIZE	W WIDTH
		UNF-2B	REF.	REF.
AJNR03	AJNL03	10-32	3/8	.160
AJNR04	AJNL04	1/4-28	7/16	.160
AJNR05	AJNL05	5/16-24	1/2	.187
AJNR06	AJNL06	3/8-24	9/16	.225
AJNR07	AJNL07	7/16-20	11/16	.250
AJNR08	AJNL08	1/2-20	3/4	.312
AJNR10	AJNL10	5/8-18	3/4	.312
AJNR10-1	AJNL10-1	5/8-18	15/16	.375
AJNR12	AJNL12	3/4-16	1 3/32	.425

METRIC STEEL JAM NUTS				
RIGHT HAND	LEFT HAND	THD. SIZE	HEX SIZE	W WIDTH
		6H	REF.	REF.
SJNR5M	SJNL5M	M5 X 0.8	3/8	.160
SJNR6M	SJNL6M	M6 X 1.0	7/16	.160
SJNR8M	SJNL8M	M8 X 1.25	1/2	.187
SJNR10M	SJNL10M	M10 X 1.5	9/16	.225
SJNR12M	SJNL12M	M12 X 1.75	11/16	.250
SJNR14M	SJNL14M	M14 X 2.0	3/4	.312
SJNR16M	SJNL16M	M16 X 2.0	15/16	.375
SJNR18M	SJNL18M	M18 X 1.5	1 3/32	.425
SJNR20M	SJNL20M	M20 X 1.5	1 3/32	.425

\* HEX SIZE MAY VARY DEPENDING ON AVAILABILITY OF MATERIAL

**NOTES:**

- JAM NUTS ARE SOLD IN LOTS OF 25 PCS. SIZE UP TO 12
- JAM NUTS ARE SOLD IN LOTS OF 10 PCS. SIZES 14-16

## CTR

### CENTER FINDERS

CENTER FINDERS ARE USED TO FIND THE LENGTH BETWEEN TWO CONNECTING RODS FOR EASE OF ASSEMBLY

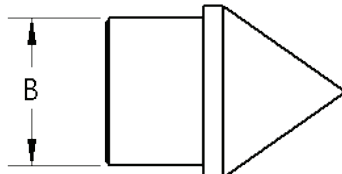

**NOTES:**

- CENTER FINDERS ARE SOLD IN PAIRS
- TO PURCHASE A COMPLETE PAIR OF EACH SIZE USE PART NUMBER CTR1

PART NUMBER	BEARING SIZE	B
CTR8	8	.500
CTR10	10	.625
CTR12	12	.750
CTR14	14	.875
CTR16	16	1.000

# RERS SERIES BOOTS

TOTALLY ENCLOSE & PROTECT YOUR ROD ENDS FROM DIRT & MOISTURE



These “boots” completely enclose the head portion of the rod end and are held in place by the mounting bolt.

The job of the boot is to completely protect the rod end from all types of contamination. In severe duty, inspect regularly for any openings that would allow dirt and water to enter.

Standard package contains size boots.

PART NUMBER	INCH SIZES	METRIC SIZES
RERS1	3/16", 1/4", 5/16"	6mm, 8mm
RERS2	3/8", 7/16"	10mm, 12mm
RERS3	1/2", 5/8", 3/4"	14mm, 16mm, 18mm
RERS4	7/8", 1"	20mm, 22mm, 25mm
RERS5	1 1/4"	30mm, 35mm

# WS SERIES SEALS

ECONOMICAL PROTECTION FOR YOUR ROD END

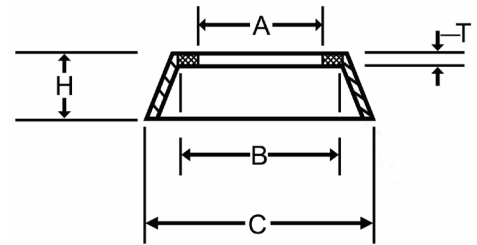

Designed to fit over the exposed portion of the rod end ball to protect against dirt and moisture. Standard package contains six individual seals, enough for three rod ends. Order by rod end size.

STANDARD SIZES							
PART NUMBER	ROD END SIZE	SIZE	A	B	C	H	T
WS1875	3	0.187	0.2	0.326	0.442	0.095	0.02
WS2500	4	0.25	0.26	0.375	0.5	0.12	0.027
WS3125	5	0.312	0.322	0.487	0.7	0.2	0.047
WS3750	6	0.375	0.385	0.53	0.8	0.22	0.047
WS4375	7	0.437	0.448	0.626	0.875	0.25	0.047
WS5001	8	0.5	0.51	0.73	1.125	0.25	0.047
WS6250	10	0.625	0.635	0.882	1.235	0.267	0.047
WS7500	12	0.75	0.76	1.006	1.381	0.367	0.047
WS1000	16	1	1.01	1.23	2.1	0.5	0.05

METRIC SIZES						
PART NUMBER	ROD END SIZE	A	B	C	H	T
WS5MM	5MM	5.25	8.28	11.22	2.41	0.5
WS6MM	6MM	6.25	9.53	12.7	3.05	1.69
WS8MM	8MM	8.25	12.37	17.78	5.08	1.2
WS10MM	10MM	10.25	13.46	20.32	5.59	1.2
WS12MM	12MM	12.25	18.54	28.58	6.35	1.2
WS14MM	14MM	14.25	18.54	28.57	6.35	1.2
WS16MM	16MM	16.25	22.4	31.7	6.8	1.2
WS18MM	18MM	18.25	22.6	32.69	8.25	1.2
WS20MM	20MM	20.25	25.15	38.1	10.16	1.2
WS25MM	25MM	25.25	33.8	53.3	12.7	1.5
WS30MM	30MM	30.25	36	55.88	13.45	1.5

**NOTES:**

One (1) rod end requires two (2) rod end seals.  
Standard packaging is six (6) seals per package.  
One pack seals three (3) rod ends.

RERS SERIES BOOTS / WS SERIES SEALS

# WELDABLE TUBE ENDS

WELDABLE TUBE ENDS

TUBE SIZE X WALL THICKNESS	10-32	1/4-28	5/16-24	3/8-24	7/16-20	1/2-20	5/8-18	3/4-16	7/8-14	1-14	1 1/4-12
3/8 X .058	1101										
1/2 X .058		1202	1203								
5/8 X .058			1303	1304	1305						
3/4 X .058			1403	1404	1405						
3/4 X .065			1503	1504	1505						
7/8 X .058				1604	1605	1606					
7/8 X .065				1704	1705	1706					
7/8 X .083				1804	1805	1806					
1" X .058				1904	1905	1906	1907				
1" X .065				2004	2005	2006	2007				
1" X .083				2104	2105	2106	2107				
1" X .095				2204	2205	2206	2207				
1 1/8" X .058						2306	2307				
1 1/8" X .065						2406	2407				
1 1/8" X .083						2506	2507	2508			
1 1/8" X .095						2606	2607	2608			
1 1/4" X .095							2707	2708			
1 1/4" X .120							2807	2808			
1 3/8" X .095							2907	2908			
1 3/8" X .120							3007	3008			
1 1/2" X .095							3057	3058			
1 1/2" X .120								3108	3109		
1 1/2" X .250								3208	3209		
1 3/4" X .120								3308	3309	3310	3311
1 3/4" X .250								3408	3409	3410	
2" X .250											3511

**NOTES:**

- FOR LEFT HAND THREAD, ADD "L" TO SUFFIX. EXAMPLE: 1706L  
\* LEFT HAND THREADED PARTS HAVE A DISTINCTIVE MARK AROUND THE OUTSIDE DIAMETER
- PART NUMBERS 2908L & 2708L AVAILABLE WITH HEX. ADD "H" TO SUFFIX. EXAMPLE: 2908L-H
- ALL TUBE ENDS ARE MADE FROM 4130 CHROMEMOLY



TUBE ENDS 2908L-H AND 2708L-H SHOWN

F.K. BEARING makes no warranties, expressed or implied, as the suitability of our Tube Ends for any application.

Tube Ends must be welded in place by a skilled welder, using proper welding techniques.

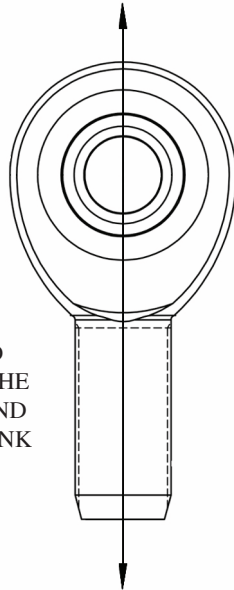

**RADIAL LOAD** - A LOAD APPLIED NORMAL TO THE BEARING BORE AXIS AND PARALLEL TO THE SHANK AXIS.

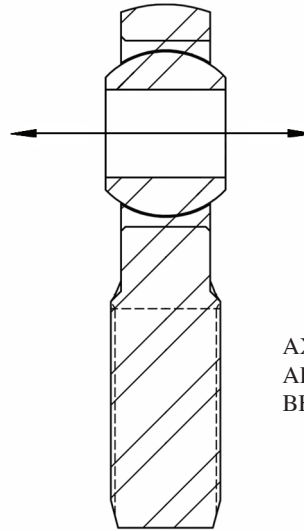

**AXIAL LOAD** - A LOAD APPLIED ALONG THE BEARING BORE AXIS

**STATIC RADIAL LIMIT LOAD** - THAT STATIC LOAD REQUIRED TO PRODUCE A SPECIFIED PERMANENT SET IN THE BEARING STRUCTURE. IT WILL VARY FOR A GIVEN SIZE AS A FUNCTION OF CONFIGURATION. IT MAY ALSO BE PIN LIMITED OR IT MAY BE LIMITED AS A FUNCTION OF BODY RESTRAINTS AS IN THE CASE OF ROD END BEARING.

**STATIC RADIAL ULTIMATE LOAD** - THAT LOAD THAT CAN BE APPLIED TO A BEARING WITHOUT FRACTURING THE BALL, RACE OR ROD EYE. THE ULTIMATE LOAD RATING IS USUALLY, BUT NOT ALWAYS 1.5 TIMES THE LIMIT LOAD.

**STATIC AXIAL LIMIT LOAD** - THE LOAD THAT CAN BE APPLIED TO A BEARING TO PRODUCE A SPECIFIED PERMANENT SET IN THE BEARING STRUCTURE.

**STATIC AXIAL ULTIMATE LOAD** - THAT LOAD THAT CAN BE APPLIED TO A BEARING WITHOUT SEPARATING THE BALL FROM THE RACE. THE ULTIMATE LOAD RATING IS USUALLY, BUT NOT ALWAYS 1.5 TIMES THE LIMIT LOAD.

## ANGLE OF MISALIGNMENT

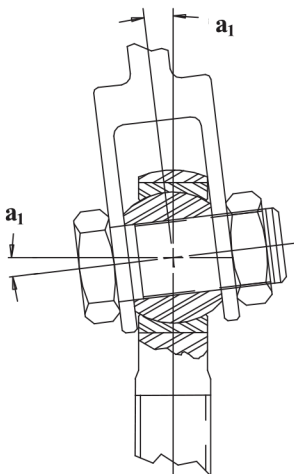

**FIGURE 1**  
 $a_1 = \sin^{-1} \frac{W}{D} - \sin^{-1} \frac{H}{D}$

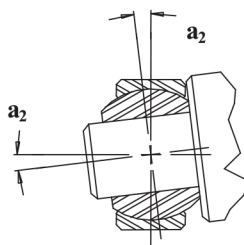

**FIGURE 2**  
 $a_2 = \sin^{-1} \frac{W}{A} - \sin^{-1} \frac{H}{A}$

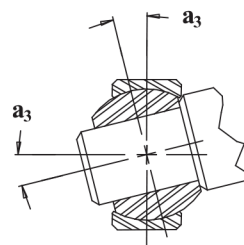

**FIGURE 3**  
 $a_3 = \sin^{-1} \frac{W}{R} - \sin^{-1} \frac{H}{R}$

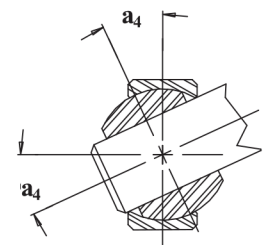

**FIGURE 4**  
 $a_4 = \cos^{-1} \frac{B}{R} - \sin^{-1} \frac{H}{R}$

- B - Ball Bore
- M - Outer Race Chamfer
- D - Head Diameter or Outer Race Diameter
- R - Ball Diameter
- H - Housing Width
- A -  $\sqrt{(D-2M)^2 + H^2}$
- W - Ball Width

# ENGINEERING DATA

## INCH/METRIC CONVERSION FACTORS

INCHES	X 25.4	= Millimeters
Millimeters	X .03937	= Inches
Sq. Inches	X 6.4515	= Sq. Centimeters
Sq. Centimeters	X .155	= Sq. Inches
Pounds	X .4536	= Kilograms
Kilograms	X 2.2046	= Pounds
Lbs. per In. <sup>2</sup>	X .0703	= kg per cm <sup>2</sup>
kg per cm <sup>2</sup>	X 14.2231	= Lbs. per In. <sup>2</sup>
Pounds (Force)	x 4.448	= Newtons
Newtons	x .2248	= Pounds (Force)
Temperature Conversion (Approximate)		
Degrees C = (Degrees F - 32) (.5556)		
Degrees F = (Degrees C) (1.8) + 32		

## Suggested Housing Bore For Press Fit of Spherical Bearings

BEARING SIZE COM SERIES	BEARING OUSTIDE DIAMETER +.0000 / -.0007	STEEL HOUSING		ALUMINUM HOUSING	
		Max.	Min.	Max.	Min.
3	.5625	.5619	.5614	.5618	.5612
4	.6562	.6556	.6551	.6555	.6549
5	.7500	.7494	.7489	.7493	.7487
6	.8125	.8119	.8114	.8118	.8112
7	.9062	.9056	.9051	.9055	.9049
8	1.0000	.9994	.9989	.9993	.9987
9	1.0937	1.0931	1.0925	1.0930	1.0923
10	1.1875	1.1869	1.1863	1.1868	1.1861
12	1.4375	1.4369	1.4363	1.4368	1.4361
14	1.5625	1.5619	1.5613	1.5618	1.5611
16	1.7500	1.7494	1.7486	1.7493	1.7485
BEARING SIZE COMH SERIES	BEARING OUSTIDE DIAMETER +.0000 / -.0007	STEEL HOUSING		ALUMINUM HOUSING	
		Max.	Min.	Max.	Min.
16	2.0000	1.9994	1.9986	1.9993	1.9985
19	2.3750	2.3744	2.3736	2.3743	2.3735
20	2.3750	2.3744	2.3736	2.3743	2.3735
24	2.7500	2.7494	2.7486	2.7493	2.7485
28	3.1250	3.1244	3.1236	3.1243	3.1235
32	3.5000	3.4994	3.4986	3.4993	3.4985

## STUDED ROD ENDS

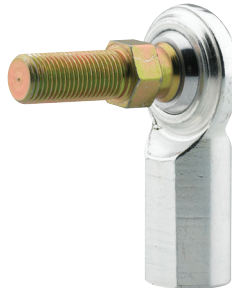
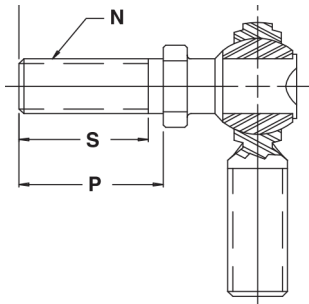

INCH SIZES					
ROD END SIZE	L LENGTH.	P LENGTH.	S LENGTH.	N THREAD	STUD HEX
	+.015 -.015	REF.	MIN.	UNF 2A	REF.
3	1.016	.500	.437	10-32	.375
4	1.031	.562	.500	1/4-28	.4375
5	1.219	.687	.593	5/16-24	.500
6	1.562	.906	.812	3/8-24	.500
7	1.750	1.062	.937	7/16-20	.5625
8	2.000	1.125	1.000	1/2-20	.625
10	2.500	1.500	1.375	5/8-18	.750
12	3.000	1.812	1.625	3/4-16	1.000

METRIC SIZES					
ROD END SIZE	L LENGTH.	P LENGTH.	S LENGTH.	N THREAD	STUD HEX
	+ .39 - .39	REF.	MIN.	MM	REF.
5	25.84	12.7	11.1	M5 X 0.8	9.52
6	26.09	14.27	12.7	M6 X 1.0	11.1
8	31.4	17.45	15	M8 X 1.25	12.7
10	44.31	27	23.8	M10 X 1.5	14.3
12	50.88	28.58	25.4	M12 X 1.75	15.88

- NOTES:
1. AVAILABLE ON ALL SERIES.
  2. STUD MATERIAL: LOW CARBON STEEL AND ALLOY STEEL (HEAT TREATED).
  3. STUD MISALIGNMENT APPROX. +/- 25 $\mu$  IN ANY DIRECTION.
  4. TO SPECIFY RIGHT HAND STUD, ADD SUFFIX "Y" TO PART NUMBER. EXAMPLE: CM6Y
  5. TO SPECIFY LEFT HAND STUD, ADD SUFFIX "YL" TO PART NUMBER. EXAMPLE: CM6YL
  6. TO SPECIFY HEAT TREATED STUD, ADD SUFFIX "YX" TO PART NUMBER (AVAILABLE ON SIZES 6-12 ONLY).
  7. FOR LOAD RATINGS WITH STUDS, PLEASE CONTACT FK ENGINEERING DEPARTMENT

NOTE: The tables above are to be used as guides only. Consult the appropriate reference to determine best size based on fit requirements, material used, etc.

ENGINEERING DATA

*Part of the Fragola family of companies...*

# **Fragola**

**Performance Systems**



**YOUR PERFORMANCE PLUMBING PARTNER**

Fragola Performance Systems  
888 West Queen Street  
Southington, CT 06489

FragolaPerformanceSystems.com  
(866) 337-2739  
(860) 621-1431 - Fax

FK Bearings, Inc.  
865 West Queen Street  
Southington, CT 06489  
U.S.A.

TOLL FREE PHONE: (800) 662-4003  
LOCAL PHONE: (860) 628-8722  
FAX: (860) 276-0463  
[www.fkrodends.com](http://www.fkrodends.com)  
[info@fkrodends.com](mailto:info@fkrodends.com)

